

TABAKALERA



PROGRAMA EN

EN



APRIL  
MAYE  
JUNE

2016

Donostia / San Sebastián

[tabakalera.eu](http://tabakalera.eu)

TABAKALERA



INTERNATIONAL  
CENTRE FOR  
CONTEMPORARY  
CULTURE

APRIL  
MAY  
JUNE

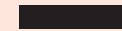

Cover

*THE DAY AFTER, Maryam Jafri*

## INDEX

04. EXHIBITIONS

14. CINEMA

22. PUBLIC  
PROGRAMMES

30. HIRIKILABS

38. EDUCATION

44. UBIK

52. ARTIST'S  
SPACE



## INTRODUCTION

We will start the quarter with two new exhibitions which we will launch on April 15: *Anarchivo SIDA* and *The Day After*, by Maryam Jafri. The first is the result of research by Equipo re about cultural production and AIDS policies and will be accompanied by a special education programme to delve into the subject. The second revolves around the concept of archive from Jafri's Independence Day, a collection of photographs from the days of independence of African and Asian colonies, which will give us the opportunity to reflect on archive issues and our colonial past, a reflection that will also extend to seminars on *Stimulants, colonialism and the crossroads of routes between Equatorial Guinea and the Basque Country*, as part of the *Stimulants: Traffic and Euphoria* project. We will also delve into the project through other meetings, such as *Café Complot* and *Smoke Policies*.

The cinema focus will be on Charles Burnett, Teresa Villaverde and Martin Rejtman, with the presence of all of them at some point. We will continue with our laboratories, this time with

the ONLSD collective, who were awarded at Clermont Ferrand, the Crater-Lab collective and Rejtman himself.

At Hirikilabs, we will pay special attention to sound and its relationship with electronics, access to information and data neutrality and the fifth call for open source projects will be launched.

In terms of things that can be enjoyed as a family, we will continue with *JoLabs* and the *Kamaleoiak gara!* series, with special guests like Maria Jerez. In April, we will première *Kamaleoiak gara!* in the morning cinema slot.

With the opening of UbiK, we can also offer a continuous service to make cultural content of the project accessible and the possibility of trying different creation tools, as well as programmes where we delve deep into the content.

There is much to do and enjoy. And we did not have enough time to tell you about everything.



# EX- HIBI- TIONS



Publication: Nunca me imaginé... (Cover detail) Concepción, Chile: CEPSS, 1995. Courtesy: Cristian Rodriguez

**ANARCHIVO SIDA**  
2016/04/15 > 2016/06/26

**Exhibition's hall opening hours**

From Tuesday to Thursday: 12:00 - 20:00

Friday: 12:00 - 21:00

Saturday: 10:00 - 21:00

Sundays and holidays: 10:00 - 20:00

2016/01/15 > 2016/04/03

Exhibition

## ARENZANA IMAZ INTXAUSTI MONTÓN PERAL

Curators: Beatriz Herráez, Peio Aguirre / Artists: Miren Arenzana, Iñaki Imaz, Gema Intxausti, Idoia Montón, Alberto Peral.  
 Exhibition hall

This exhibition, is a collective exhibition of five artists who started their career, linked to the Basque Country, in the 1990s. The artists in the exhibition are Miren Arenzana, Iñaki Imaz, Gema Intxausti, Idoia Montón and Alberto Peral, who are characterized by the use of mainly painting and sculpture, as well as opening their practices to areas that include writing, photography, video and design. The aesthetic uniqueness of each of these artists is more than enough for an X-ray of the Basque art scene in the last two decades.

1 APRIL (Friday)

Visit

### VISIT IN DIALOGUE

18:00-19:00 Spanish  
 19:00-20:00 Basque

Registration: [www.tabakalera.eu](http://www.tabakalera.eu) or at the information point  
 Exhibition hall

These visits offer various tours and dialogues with the aim of getting closer to the content.

2 APRIL (Saturday)

Presentation

### PRESENTATION OF THE CATALOGUE ARENZANA IMAZ INTXAUSTI MONTÓN PERAL

With the curators and artist  
 11:00  
 UBIK, Living room

2016/04/15 > 2016/06/26

Exhibition

## THE DAY AFTER AN EXHIBITION BY MARYAM JAFRI

Exhibition hall

Tabakalera presents an exhibition by the artist Maryam Jafri: *The Day After*. An exhibition in which the artist investigates different photographic archives, where the days of declaration of independence in countries in Africa and Asia that were European colonies in the past are portrayed. The decolonisation processes and different discourses generated around them constitute the core of this project. Paying particular attention to photographic images and their circulation and reading, Maryam Jafri offers different readings on history, in which a variety of factors and characters take part.

*The Day After*. An exhibition by Maryam Jafri is a co-production between Bétonsalon, an art and research centre in Paris, and Tabakalera, in collaboration with Danish Art.

### RELATED ACTIVITIES

15 APRIL (Friday)

#### INAUGURATION OF THE EXHIBITION

19:00  
 Exhibition hall

16 APRIL (Saturday)

#### BREAKFAST WITH THE ARTIST

Maryam Jafri and Elvira Dyangani Ose  
 11:00  
 Exhibition hall, meeting space

Conversation between the artist Maryam Jafri and Elvira Dyangani Ose. The artist and the curator, who have worked previously on other projects, will talk about the exhibition.

5 and 6 MAY

Workshop and round table

#### IMAGE AND MEMORY OF COLONIAL SPAIN

An offering from Inés Plasencia  
 Guests: Francesca Bayre, Suset Sánchez and Carlos Ndungmandum

The thread of this series of activities is based around various aspects of what has been called "the colonial archive", particularly regarding the visual material, both in film and in photographs. These aspects are: the colonial memory and archive material; the management of and narrative material in digital files and "social life" and future of the archive material.

5 MAY (Thursday)

Workshop

#### ARCHIVAL VIOLENCE. WORKSHOP ON COLONIAL PHOTOGRAPHY ARCHIVES

Presented by Inés Plasencia  
 10:00-14:00  
 Registration: [www.tabakalera.eu](http://www.tabakalera.eu) or at the information point  
 Workshop

6 MAY (Friday)

Screenings and Round table

#### IMAGE AND MEMORY OF COLONIAL SPAIN. DOCUMENTARIES ABOUT THE EQUATORIAL GUINEA OF MANUEL HERNANDEZ SANJUAN

17:00-20:00  
 Z Hall

Screening of a selection of short films and a round table with the participation of Francesca Bayre (Anthropologist), Suset Sánchez (Critic and exhibition curator) and Carlos Ndungmandum (Photographer), moderated by Inés Plasencia.

19 y 20 MAY

Seminar

#### TOUCH DEVICES: CURATORIAL RESEARCH ON SPANISH SOVEREIGN TERRITORIES

An offering from Leire Vergara

This seminar is dedicated to the introduction of the project *Touch Devices: Curatorial Imagination in the Times of Expanded Borders* produced in 2015 in collaboration with Trankat Résidence d'artistes en médina de Tétouan (Trankat art residency in Tetouan's medina), which is part of the doctoral research of Leire Vergara within the *Curatorial /*

*Knowledge* programme of the *Visual Cultures* department at Goldsmiths College, University of London. This seminar addresses the crossover that occurs between curatorial practice and academic research and has a number of guests involved in different stages of developing this research, who will give an account of marginalised spaces that emerge beyond this process.

Guests: Younès Rahmoun (Tetuan), Mohamed Larbi Rahhali (Tetuan), Marion Cruza Le Bihan (Bilbao), Xabier Salaberria (San Sebastian) and Irit Rogoff (London).

**19 MAY** (Thursday)  
**LECTURE BY IRIT ROGOFF**  
**19:00**  
 ♻ Z Hall

**20 MAY** (Friday)  
**Artist presentations**  
**EPHEMERAL INSTALLATION BY MOHAMED LARBI RAHHALI**  
**19:00 – 21:00**  
 ♻ Workshop

19:00 **Younès Rahmoun**  
 19:30 **Xabier Salaberria**  
 20:00 **Marion Cruza Le Bihan**

**4 JUNE** (Saturday)  
**Public call + viewing**  
**THE PHILIPPINES. PHOTOGRAPH ALBUMS OF OUR FAMILY**  
**12:00**  
 ♻ Z Hall

Shared viewing of albums of Basque families who have had a relationship with or are related to the Philippines.

With regard to the case study dedicated to the Philippines in the exhibition hall, anyone who has had or currently has some kind of relationship with the Philippines is invited to attend with their family photo albums to share experiences and family adventures, which, being micro-stories, are part of the story.

**EDUCATION PROGRAMME**

**29 APRIL, 13** (Servicio ILSE), **27 MAY, 10, 24 JUNE** (Friday)  
**Visit**  
**VISIT IN DIALOGUE**  
**18:00-19:00 Spanish**  
**19:00-20:00 Basque**  
 Registration: [www.tabakalera.eu](http://www.tabakalera.eu) or at the information point  
 ♻ Exhibition hall

From the contents of the exhibitions, we will create opportunities for dialogue in which we will link these contents with our knowledge and experiences. We will generate multiple discussions and tours to enrich each visit.

**27 APRIL** (Wednesday)  
**Visit**  
**EXPERIMENTAL VISIT**  
**18:30**  
 Registration: [www.tabakalera.eu](http://www.tabakalera.eu) or at the information point  
 ♻ Exhibition hall

These visits represent a number of experimental visions of the exhibition with the aim of opening it up to new interpretations.

**8 JUNE** (Wednesday)  
**Visit**  
**EXPERIMENTAL VISIT**  
**18:30**  
**Jeanne-Rolande Dacogna Minkette**  
 Registration: [www.tabakalera.eu](http://www.tabakalera.eu) or at the information point.  
 ♻ Exhibition hall

Jeanne-Rolande Dacogna Senegalese-born researcher and feminist activist from San Sebastian. She will provide a dialogue with the exhibition, relating its content to migratory processes.

**2016/04/15 > 2016/06/26**  
**Exhibition**  
**ANARCHIVO SIDA**  
 Curators: Equipo re (Aimar Arriola, Nancy Garín and Linda Valdés)  
 Design: Carme Nogueira  
 Participants: ACT UP (Barcelona & Latino Caucus NY), Águeda Bañón, Miguel Benlloch, CEPSS Centro de Educación y Prevención en Salud Social y SIDA - Chile, Francisco Copello, Diego del Pozo Barriuso, Santiago Echeverry, EHGAM - Euskal Herriko Gay-Les Askapen Mugimendua, Pepe Espaliú, Rafael França, Antonio Gagliano, Iñaki Garmendia, La Radical Gai, Las Pekinesas, Las Yeguas del Apocalipsis (Archivo Web D21), LSD, Nicolás Malevé, Pepe Miralles, Guillermo Moscoso, MUMS Movimiento por la Diversidad Sexual - Chile, José Osorio, Daniel Palma, Miguel Parra Urrutia, Andrés Senra, The Carrying Society, TV SIDA.

The exhibition *Anarchivo sida* is the result of a process of research and production by the collective Equipo re. It takes cultural production about the AIDS crisis in southern Europe and Latin America as its starting point. The exhibition will address the classic nature / culture articulation through three issues: the historical trend of dividing humans from animals; the cultural dimension of death; and health, understood as the convention by which some bodies are considered normal and others sick. Overall, the exhibition will feature content from the mid-eighties to the present with materials that have never been assembled together.

*Anarchivo sida* is a research and production project led by Equipo re, which is presented in an exhibition format and programme of activities, co-produced by DSS2016EU and Tabakalera.

**RELATED ACTIVITIES**

**15 APRIL** (Friday)  
**MEETING WITH THE CURATORS**  
**17:00 - 18:00**  
 Free entrance until seating capacity is full  
 ♻ Z Hall

**15 APRIL** (Friday)  
**INAUGURATION**  
**19:00**  
 ♻ Exhibition hall

MARCH > JUNE

Workshop

**THE NAMES WORKSHOP**

Times and places to be defined with the groups. Participants: associations, social groups and school groups.

To name and be named is a fundamental political issue. In the context of the policies on HIV/AIDS, epithets such as (Affected), "carrier", "sick", "infected" will serve to mark the limits and privileges of some bodies with respect to others. The Names Workshop works in this field and is proposed as an exercise to review and put forward demands/claims for names that affect us. The results of the workshop will be reflected in the construction of a map courtesy of the illustrator Josune Urrutia.

APRIL > JUNE

Programme of presentations

**HEALTH / KNOWLEDGE / POWER**

The need to intervene in medical knowledge was fundamental for people diagnosed early with HIV. The change in relationship between health, knowledge and power, which led to the first AIDS activism, is the starting point for this activity, which seeks to activate an exchange network between different forms of practical knowledge on the political management of the body. The activity focuses on 5 sessions of conversation and debate on issues such as HIV/AIDS, ecology

and food, functional diversity, the legal system and migration. Local coordinator of the programme: Josebe Iturrioz.

**April 16: HIV/AIDS.** Christian Rodriguez, Asociación Harribeltza. 17:00 ♣ Workshop

**May 7: Environment / Food.** Edurne Epelde and Consuelo Infante. 14:30 ♣ Workshop

**May 27: Functional diversity and non-regulatory bodies.** Las Raras and Urko (Post Op). 17:00 ♣ Workshop

**June 11: The legal system.** Hibai Arbide and Juana Balmaseda. 17:00 ♣ Workshop

**June 25: Mobility of bodies / Immigration / Border management.** Brais Varela, Salvamento Marítimo Humanitario, Nadia Jabr. 17:00 ♣ Garoa

**28 MAY (Saturday)**  
**LISTENING PROTOCOLS: TRUE IN MY BODY**

*Miren Jaio, Jesús Jeletón, Héctor Rey, Susana Talayero, Maia Villot*  
**10:00 - 14:00 and 16:00 - 19:00**  
Free entrance until seating capacity is reached  
♣ Exhibition hall

From the invitation from Equipo re to the artist Jesús Jeletón to generate an intervention at *Anarchivo sida* from the idea of "listening protocols", he called Miren Jaio, Héctor Rey, Susana Talayero and Maia Villot to produce a series of interventions for the exhibition from the body and the political potential of listening.

MAY > JUNE

Performance programmes  
**BODIES IN THE GAP**

Performance programme that explores the body from "the gap between discourse and materiality" (Peggy Phelan), from strategies like the explicit body, animality as strength or the recourse to touch.

**May 7:** Miguel Benlloch, *Dererumnatura: quien canta su mal espanta.*

18:00 ♣ Exhibition hall

**June 10:** Aimar Pérez-Galí, *The Touching Community.*

19:00 ♣ Sala Z

**June 24:** Quimera Rosa, S.I. *performance duracional one by one.*  
19:00 ♣ Exhibition hall

**EDUCATION PROGRAMME**

**26 APRIL; 10 MAY; 14 JUNE**  
(Tuesdays)

Learning Group

**TESTU-INGURUAN**  
**18:00-20:30 EU+ES**

Registration: [www.tabakalera.eu](http://www.tabakalera.eu) or at the information point

Testu-inguruan is a learning group that accompanies Tabakalera exhibitions. We review materials such as texts, films or parts of the exhibitions or others related, with the intention of educating ourselves, little by little, on issues related to contemporary art.

**18 MAY (Wednesday)**

Visit

**EXPERIMENTAL VISIT**

Guest *tbc*

**18:30**

Registration: [www.tabakalera.eu](http://www.tabakalera.eu) or at the information point  
♣ Exhibition hall

This visit offers a experimental perspective on the exhibition to open it up to new interpretations.

**22 JUNE (Wednesday)**

Visit

**EXPERIMENTAL VISIT**

**18:30**

Registration: [www.tabakalera.eu](http://www.tabakalera.eu) or at the information point  
♣ Exhibition hall

The education team, will propose getting closer to the exhibition from the use of language and its performativity.

2016

Exhibition

## MAÑANA GOODBYE. GRUPO DE MUJERES QUE TRABAJAN JUNTAS.

Chapters 7, 8, 9

Coordination: Marión Cruza, Pablo Marte

📍 Storage

12-part series that explores the changing production model by which the old Tabacalera factory became the current International Centre for Contemporary Culture. Lurking two big questions: what do we need from the past when it comes to work? and how and from where one can speak of memory?. Tabakalera embodies these and many other issues, which has allocated a small space in the building, Storage, where the series is shown as a video installation, adding a chapter each mid-month, starting from the inauguration on September 11, until September 2016. The project will be accompanied by a public side events from March on.

### RELATED ACTIVITIES

#### AFTER LEAVING THE FACTORY

*After leaving the factory* is a programme of activities which accompanies *Mañana Goodbye* project. After leaving the factory starts with off-plane scenes that follow two films that inaugurate the story of cinema in 1895: *Train Arriving at the Station* and *Workers Leaving the Lumière Factory in Lyon* by Louis Lumière. This will be the first of four meetings. Each starts with a possible scene of "after leaving the factory". Films will be shown at all. We will also stop watching them for a while as the best way of paying attention. *After leaving the factory* aims to discuss matters such as cinema and work, work and gender, experience and memory, individual and collective subjects or the productive and the unproductive.

7 APRIL (Thursday)

Conversation

#### AFTER LEAVING THE FACTORY 2

*Miren Jaio: Otzarutxu bat, otzarutxu bi*  
19:00

📍 Storage

"The workers leave the factory. Some run to the market before it closes. Others go to collect their children on the way home. They all go somewhere in a hurry. Work never seems to finish".

Installation

#### MEETING OF THE PROJECT ROOM

2016/05/27 > 2016/09/04

URSUS<—> TABAKALERA

Artista: Jasmina Wójcik

27/05/2016 > 04/09/2016

Artist: Michał Frydrych

From Monday to Sunday: 10:00-20:00

📍 Hall planta 2

These two instalations are part of the project *Meeting of the Project Room* coordinated by Magda Kardasz, which presents the work of three young polish artists. The invited artists – Jaśmina Wójcik, Michał Frydrych and Natalia Bażowska, represent different creative approaches. They will all present the outcomes of their activities carried out explicitly within the space of the Tabakalera, referring to the local context or history of the space. All of them were the authors of site-specific installations at the Zachęta Project Room, during the last three years of its activity.

This project has been produced for Tabakalera with the collaboration of Polish Institute in Madrid.

APRIL

Installation

#### THE WALL: ONLSD

From Monday to Sunday: 10:00-20:00

📍 Aisle floor 1

#### Eden's Edge / Three Shorts on the Californian Desert

"*Eden's Edge* is a film portrait in three parts about Hollywood's probably most prominent landscape icon from the viewpoint of people living there. Initially marked by exceptional directorial sobriety, we see bird eye views of minimalistic scenes, meticulously arranged in gray desert sands, usually furnished with very few props. Within this context, barely insect size inhabitants move about hermits, mavericks and freaks in the best sense of the word. They all have retreated to the desert, to reinvent their lives on the margins of an increasingly unbearable society. Rarely have borders of the idyllic been so concisely drawn; rarely have places of retreat remaining for non conformists been pinpointed so precisely". Christian Höller





**Dos disparos**  
Martin Rejtman

# CINE- MA



**Tickets:**

- [www.tabakalera.eu](http://www.tabakalera.eu)
- At the information point
- At the box office, 30' minutes before the session
- Price: 3,50€



**APRIL**

**FOCUS: CHARLES BURNETT**

In collaboration with the Play-Doc International Documentary Festival.

"I think a strong case can be made that Charles Burnett is the most gifted and important black film maker this country has ever had. But there's a fair chance that you've never heard of him...."

Jonathan Rosenbaum, American film critic.

Watts was, and still is, one of these tough neighbourhoods in Los Angeles where gangs and ethnic minority communities live in a delicate balance with the police. Burnett (Vicksburg, Mississippi, 1944) came to Watts in 1947, so all of his memories of childhood and youth are linked to the neighbourhood, which would later become material for his films. It was at the University of California, in the cinema and ethno-communications department, that Burnett began to give form to his imagination and where, together with other film makers, he created the L.A. Rebellion, a creative, political space to give a voice to the most disadvantaged communities. Burnett is considered a neo-realist director: in his films he portrays a direct, raw reality, but without ever neglecting lyricism, aesthetics and a humanist quest. Using his method of "approaching reality and showing what it hides", Burnett was always a political director and, in this review of his filmography, we will learn about his thinking and his most emblematic works. The focus on his films and visit of the film maker will be completed

with the joint publication (together with the Play-Doc International Documentary Festival) and presentation of the first world monograph dedicated to the African American author: *Charles Burnett, full of anger but without hate*.

Charles Burnett will attend, along with Victor Paz, coordinator of the publication.

**15 APRIL** (Friday)

**Killer of Sheep**, USA, 1977, 80'  
**21:00** ♡ Cinema

**22 APRIL** (Friday)

**My Brother's Wedding**, USA / Germany, 1983, 81'  
**Presentation and chat between the director, Charles Burnett, and the editor of the book about his work, Victor Paz.**  
**21:00** ♡ Cinema

**30 APRIL** (Saturday)

**When it rains**, 1995, USA, 13'  
**To sleep with anger**, 1990, USA, 102'  
**19:00** ♡ Cinema

**MAY**

**FOCUS: TERESA VILLAVERDE / SEASONS: OH PORTUGAL!**

The question that gives meaning to this focal point is very clear: Why don't we know Teresa Villaverde's films? The director from Lisbon (1966), present with her five feature films on the international festival circuit, head visible next to Pedro Costa from the so-called third generation of Portuguese cinema, but completely unknown in our cinemas... It is the time, therefore, to devote our screen and the month of the Oh Portugal! season to Teresa Villaverde: we will show three of her

feature films and invite the director to programme a classic of Portuguese cinema.

**6 MAY** (Friday)

**Teresa Villaverde 1**  
**21:00** ♡ Cinema

**13 MAY** (Friday)

**Teresa Villaverde 2**  
**21:00** ♡ Cinema

**20 MAY** (Friday)

**Teresa Villaverde 3**  
**21:00** ♡ Cinema

**27 MAY** (Friday)

**Teresa Villaverde chooses a film from the history of Portuguese cinema.**  
**21:00** ♡ Cinema

**JUNE**

**FOCUS: MARTÍN REJTMAN**

"My job is to look, listen and, based on this, write or film. I work a lot with observation, with things that happen to me, that people tell me or that I see. I process everything in a strange way and it becomes a story or a script. And before I start writing or decide what I'm going to shoot, I study the area." Martín Rejtman.

Argentine writer, screenwriter and film director (Buenos Aires, 1961), Rejtman is one of those directors of whom one can be a big fan. We are: of his films and his characters, of his rare comedies, of how he films Buenos Aires, of how his characters walk, dance, listen to music and run, of his portraits, of his "special" rhythm (neither very fast or very slow), of the titles of his works, of his way of combining writing, cinema and style, of the everyday life and

smallest details of his plots, of how they grow after his films, and, in short, of his way of understanding and creating cinema and literature. This is the Rejtman territory: a retrospective to his work, a workshop on cinema and writing and a carte blanche.

**3 JUNE** (Friday)

**Doli vuelve a casa**, Martin Rejtman, Argentina, 1986, 30'  
**Rapado**, Martin Rejtman, Argentina, 1992, 75'  
**20:00** ♡ Cinema

**10 JUNE** (Friday)

**Silvia Prieto**, Martin Rejtman, Argentina, 1999, 92'  
**20:00** ♡ Cinema

**11 JUNE** (Saturday)

**Los guantes mágicos**, Martin Rejtman, Argentina, 2003, 90'  
**21:00** ♡ Cinema

**17 JUNE** (Friday)

**Dos disparos**, Martin Rejtman, Argentina, 2014, 105'  
**20:00** ♡ Cinema  
**Presentation and chat with the director.**

**18 JUNE** (Saturday)

**Entrenamiento elemental para actores (Elementary Training For Actors)**, Martin Rejtman and Federico León, Argentina, 2009, 52'  
**19:00** ♡ Cinema

**Copacabana**, Martin Rejtman, Argentina, 2006, 56'  
**21:00** ♡ Cinema

**24 JUNE** (Friday)

**Carte blanche to Martín Rejtman.**  
**20:00** ♡ Cinema

**OHPORTUGAL!**

We continue with the season focused on. Portuguese cinema. Once a month we invite a contemporary filmmaker to present their work and to choose a film related to Portugal that is a reference for their career.

**1 APRIL** (Friday)

**Ceci n'est pas Gabriel Abrantes: a selection of his short works) 87'**  
**20:00** ♡ Cinema

**Presentation and chat with the director.**

**Taprobana**, Gabriel Abrantes, Portugal, 2014, 23'

**Ennui Ennui**, Gabriel Abrantes, France, 2013, 34'

**A History of Mutual Respect**, Gabriel Abrantes and Daniel Schmith, Portugal, 2010, 23'

**Olympia I**, Gabriel Abrantes, Portugal, 2008, 3'

**Olympia II**, Gabriel Abrantes, Portugal, 2008, 4'

**29 APRIL** (Friday)

Film chosen by Gabriel Abrantes.  
**Tras os Montes**, Antonio Reis and Margarida Cordeiro, Portugal, 1976, 111'

**20:00** ♡ Cinema

**MAY: Teresa Villaverde** (+ Info: Focus dedicated to her)

**JUNE: Season** (author to be confirmed)

**EUROPA, FUTURE PAST**

Programme curated by Pablo La Parra under the framework of the research residency that Tabakalera and the Donostia San Sebastián 2016 Foundation launched jointly. The Europe, future past project explores

transfers between the militant film archive and contemporary visual and artistic practices.

**21 MAY** (Saturday)

**Nightcleaners**, Berwick Street Collective, 1975, United Kingdom, 90'  
**19:00** ♡ Cinema

**Presentation by teacher and programmer Elena Oroz.**

**4 JUNE** (Saturday)

**À bientôt j'espère**, Chris Marker and Mario Marret, 1967-1968, France, 45'

**La charnière** (Solo audio), Antoine Bonfanti and Pol Cèbe, 1969, 13'

**On ira à Neully Inch'Allah**, Anna Salzberg and Mehdi Ahoudig, 2015.

**19:00** ♡ Cinema

**Presentation by Amador Fernández-Savater and David Cortés.**

**THE ATOMIC AGE**

We continue with the cycle on images of childhood, adolescence and youth in film. We combine this programme with premieres of films that are now touring festivals, a review of classics and a session scheduled and presented each month by the ZOOM video laboratory group of teenagers, activated by the Mediation area of Tabakalera and Instituto Usandizaga.

**3 APRIL** (Sunday)

**Next**, Elia Urquiza, USA/Spain, 72'  
**18:00** ♡ Cinema

**Chat on Skype with the director.**

**10 APRIL** (Sunday)

**La clase (Entre les murs) (The Class)** Lauren Cantet, France, 2008, 128'

**18:00** ♡ Cinema

**17 APRIL** (Sunday)

**Mes petites amoureuses, (My Little Loves)**, Jean Eustache, France, 1974, 123'

**18:00** ♡ Cinema

**24 APRIL** (Sunday)

**ZOOM**  
**18:00** ♡ Cinema

**1 MAY** (Sunday)

**Pather Panchali ((My Little Loves)**, Satyajit Ray, India, 1955, 115'  
**18:00** ♡ Cinema

**8 MAY** (Sunday)

**Aparjito (The Unvanquished)**, Satyajit Ray, India, 1956, 105'  
**18:00** ♡ Cinema

**15 MAY** (Sunday)

**Apur Sansar (The World of Apu)**, Satyajit Ray, India, 1959, 117'  
**18:00** ♡ Cinema

**22 MAY** (Sunday)

**Paperboys**, Mike Mills, USA, 2001, 41'  
**Amarillo by morning**, Spike Jonze, USA, 1998, 29'  
**18:00** ♡ Cinema

**29 MAY** (Sunday)

**ZOOM**  
**18:00** ♡ Cinema

**5 JUNE** (Sunday)

**Poto y Cabengo**, Jean Pierre Morin, USA, 1980, 73'  
**18:00** ♡ Cinema

**12 JUNE** (Sunday)

**Welcome to F.L.**, Genevieve Dulude-DeCelles, Canada, 2015, 75'  
**18:00** ♡ Cinema

**19 JUNE** (Sunday)

**En Kärlekshistoria (A Swedish Love Story)**, Roy Andersson, Sweden, 1970, 115'

**18:00** ♡ Cinema

**26 JUNE** (Sunday)

**ZOOM**  
**18:00** ♡ Cinema

**CARTES BLANCHES**

Invitation to festivals, critics, artists and international programmers to enable access to our screen and to establish working partnerships and dialogue.

**2 APRIL** (Saturday)

**Cecilia Barrionuevo**, programmer of the Mar de Plata International Film Festival

**El movimiento**, Benjamín Naishtat, Argentina and South Korea, 2015, 70', DCP  
**19:00** ♡ Cinema

**Presentation and chat with Cecilia Barrionuevo.**

**CONTEMPORARY CINEMA**

Films from the international festival circuit and independent distributors. Each film will have three screenings.

**8 APRIL** (Friday)

**AKOSUA ADOMA OWUSU: SELECCIÓN DE SUS TRABAJOS CORTOS. 68'**

Akosua Adoma Owusu (1984) is a Ghanaian-American director who explores the creative and critical tension between her roots and experience in the American diaspora in her work. Topics such as culture, gender, identity and post-colonial African history are present in her work, proposing a reflection on what the film maker calls the warring consciousness of African immigrants in the United States.

**Intermittent Delight**, USA, 2007, 5'  
**Me Broni Ba (My White Baby)**,

Ghana/USA, 2009, 22'

**Drexciya**, Ghana/USA, 2010, 12'

**Split Ends, I Feel Wonderful**, USA, 2012, 4'

**Kwaku Ananse**, Ghana/México, USA, 2013, 25'

20:00 ♡ Cinema

Presentation and chat between the director, Akosua Adoma Owusu, and curator of the season, Beatriz Leal.

16 APRIL (Saturday)

**Informe general (General Report)**,

Pere Portabella, Spain 1976, 154'

19:00 ♡ Cinema

23 APRIL (Saturday)

**Informe General II, el nuevo rpto de Europa (General Report II: The Rape of Europe)**,

Pere Portabella, 2015, Spain, 126'

19:00 ♡ Cinema

7 MAY (Saturday)

**Malpartida Fluxus Village**, María

Pérez, Spain, 2015, 73'

Presentation and chat with the director.

19:00 ♡ Cinema

14 MAY (Saturday)

**Lu Bian Ye Can (Kaili Blues)**, Bi

Gan, China, 2015, 110'

19:00 ♡ Cinema

28 MAY (Saturday)

CONTEMPORARY CINEMA

19:00 ♡ Cinema

25 JUNE (Saturday)

**Yo no soy de aquí í (I'm Not From Here)**,

Maite Alberdi, Chile, 2016, 25'

**La once (Tea Time)**, Maite Alberdi,

Chile, 2014, 70'

19:00 ♡ Cinema

## MORNING SESSIONS

Z Hall is our experimental room

where anything can happen:

presentation of audiovisual projects,

films in their original 16mm format

and new audiences.

24 APRIL (Sunday)

MATINAL FAMILIAR 70'

12:00 ♡ Z Hall

1 MAY (Sunday)

BRUCE BAILLIE

The curator Garbiñe Ortega presents

the 16 mm work of this American

film maker.

12:00 ♡ Z Hall

PART ONE: LET'S NOT BE SO SERIOUS ABOUT ART – CANYON CINEMA COMMUNITY.

**The Bed**, James Broughton, 1968, 20'

**Angel Blue Sweet Wings**, Chick

Strand, 1966, 3'

**Riverbody**, Anne Severson, 1971, 7'

PART 2: ALL MY LIFE, THE CINEMA OF

BRUCE BAILLIE.

**Mr Hayashi**, Bruce Baillie, 1961, 3'

**Mass for Dakota Sioux**, Bruce

Baillie, 1964, 20'

**Valentin de las Sierras**, Bruce

Baillie, 1971, 10'

**To Parsifal**, Bruce Baillie, 1963, 16'

**All my Life**, Bruce Baillie, 1966, 3'

8 MAY (Sunday)

PANTALLA FANTASMA, PRESENTATION OF THE 5TH EXHIBITION OF STRANGE CINEMA.

Jorge Núñez + Elvis Rever + Sergi

Botella

12:00 ♡ Z Hall

Pantalla Fantasma is an audiovisual

exhibition that explores the limits

of image and sound. For the third

consecutive year, Jorge Núñez, its director, will present a summary of the latest edition in San Sebastian and invites artists from the works screened.

5 JUNE (Sunday)

FAMILY MORNING SESSION 70'

12:00 ♡ Z Hall

12 JUNE (Sunday)

FRAME-BY-FRAME: A SELECTION CURATED BY ELENA DUQUE.

12:00 ♡ Z Hall

The curator Elena Duque presents

a selection of works made frame-by-

frame on 16 mm.

**Persian Pickles**, Jodie Mack, 2012, 3'

**Trial Balloons**, Robert Breer, 1982, 6'

**3/60 Trees in Autumn**, Kurt Kren,

1960, 3'

**La Pêche Miraculeuse**, Cécile

Fontaine, 1995, 10'

**Sidewinder's Delta**, Pat O'Neill,

1976, 20'

**Bouquets 25-27**, Rose Lowder,

2002-2003, 4'

**Thunder**, Takashi Ito, 1982, 5'

**Cineblatz**, Jeff Keen, 1968, 3'

## LABORATORIES

Registration: [www.tabakalera.eu](http://www.tabakalera.eu) or at the information point

### LABORATORY 04: ONLSD COLLECTIVE

25 - 29 APRIL (Monday-Friday)

10:00-14:00

And if the nature of the landscape was narrative? What would it tell us?

Laboratory presented by the Office for Narrative Landscape Design (ONLSD) collective:

"The aim of our workshop is to question the divide between fiction and reality. We want to explore and renegotiate the world in which we live with cinematographic techniques."

ONLSD won the Grand Prix in the Labo section of the 2016 Clermont Ferrand Short Film Festival.

### LABORATORIO 05: OPTICAL PRINTER

23 - 26 MAY (Monday-Thursday)

Luis Macías, of the Crater-Lab collective from Barcelona, will present a workshop on the optical printer, a small special effects machine used by experimental film makers to create their films on 16 mm film.

This is pure analogue, this is copying and pasting on celluloid, this is a cinema without a camera, this is developing in the Tabakalera studio, this is playing with your hands and imagination.

### LABORATORY 06: MARTÍN REJTMAN

13 - 17 JUNE (Monday-Friday)

Workshop on writing and cinema with Argentine film maker, Martín Rejtman.

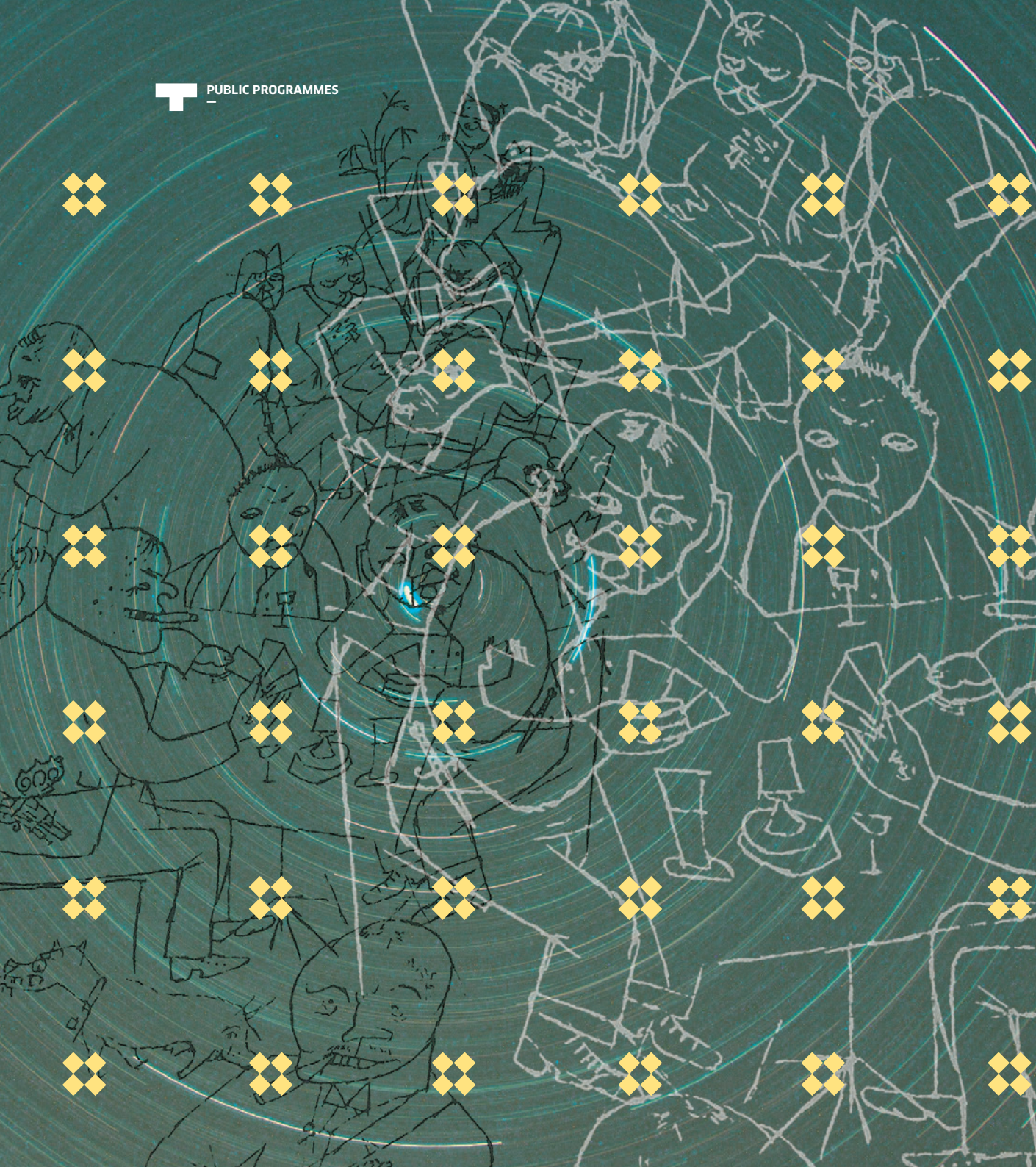

# PUBLIC PROGRAMMES

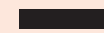



## STIMULANTS: TRAFFIC AND EUPHORIA

*Stimulants: Traffic and Euphoria* is a programme that revolves around modern stimulant. It includes public discussions, expository essays, music festivals, working groups, seminars, film screenings and publications. This programme will extend until 2017.

**21 - 22 APRIL** (Wednesday-Thursday)

Meetings

### CAFÉ COMPLIT

Coordinated by *Ignacio Echeverria*.  
*Philologist, editor and literary critic.*  
**18:00-21:00**

📍 Z Hall

This offering, curated by Ignacio Echeverria for *Stimulants: Traffic and Euphoria*, is a two-fold choral reflection on coffee: on the one hand, as a substance that often serves as an escape at work time and, on the other, «the café», as the embryonic environment of the so-called 'public sphere', a meeting place in the 18th century for a contentious bourgeoisie, who hatched their programme of emancipation and democratisation in cafés and which signalled the directions in which ideologies and literary and artistic currents of modernity had to evolve.

**21 APRIL** (Thursday)

*Ignacio Echeverria, Adan Kovasics, Antonio Martí Monterde, Gonzalo Torné, and Oier Etxeberria.*

Having a coffee is, in itself, only a ritual involving one of linear and productive time, hence the consumption of coffee, both at

home and in public, has given rise to new forms of sociability, but also loneliness. This first session will reflect on coffee "time", on the café as the "interior" of the city, on the writing and poetics of the café, on the relationship between coffee and literature.

**22 APRIL** (Friday)

*Ignacio Echeverria, Harkaitz Cano, Cecilia Dreymuller, Nora Catelli and Oier Etxeberria*

In 18th-century England, cafés articulated the conscience of the emerging bourgeoisie and constituted the germ of what is meant by "public sphere". Since then, the café, with its multiple mutations and different forms, depending on the country, has been the key stage for many decisive episodes of the modern age. This round table will reflect on the cultural, political and sociological scope of the café and its different "versions" in Europe. Also on the subversive dimension of the café and about its relationships with the avant-garde.

**28 APRIL, 26 MAY, 30 JUNE**  
(Thursdays)

Programme of lectures

### SMOKE POLICIES

**19:00**

📍 Z Hall

*Smoke, policies* is a programme of monthly lectures by artists, anthropologists, writers and art historians that falls under the project *Stimulants: Traffic and Euphoria*. *Smoke policies* is also an exercise in invocation and possession, in which the voices of philosophers, poets,

politicians or chemists will occupy the bodies of these guests throughout the year.

**28 APRIL** (Thursday)

### DRUGS AND EUPHORIA IN THE WORK OF ERNST JÜNGER

*Xabier Arakistain / Albert Hofmann*

This is a lecture that Albert Hofmann gave in Bilbao on October 18, 1989, in a symposium-homage to the German philosopher, writer and historian Ernst Jünger. Both of them shared an interest in altering perceptions and states of mind through the use of substances, with the aim of widening the horizons of consciousness and human thought. The lecture highlights the importance of these experiences in the forming of Ernst Jünger's thoughts and their links to the problems that were emerging in the fields of philosophy and science at that time.

**26 MAY** (Thursday)

### ZER DA URA?

*Danele Sarriugarte / David Foster Wallace*

David Foster Wallace will start the lecture which he gave to graduates of Kenyon College with a fable. Fish and water are the main characters, as while we are swimming we do not notice the presence of water, its necessity. Sarriugarte will put footnotes to Wallace, in such a way that some of the elements that make up the water supporting him appear.

**30 JUNE** (Thursday)

### DREAMS AND LITERARY CREATION

*Valentin Roma / María Zambrano*

The thinking of María Zambrano has been persistently invoked from three forms of nostalgia: political nostalgia for the effects of the civil war and exile for some of the most important intellectuals of the time; philosophical nostalgia for a strictly Spanish school that sums up tradition and the future; poetic nostalgia for a language, which, leaning towards spirituality, does not exclude precision, which, trying to name what is sacred, does not avoid being biting. Perspectives that make up a reductionist image that this staging will try to circumvent.

**15-17 JUNE** (Wednesday-Friday)

Lectures programme

### STIMULANTS, COLONIALISM AND THE CROSSROADS OF ROUTES BETWEEN EQUATORIAL GUINEA AND THE BASQUE COUNTRY

The purpose of these seminars is to provide information and food for thought on the crossover of two kinds of relationship between Equatorial Guinea, Spain and the Basque Country in the form of words, images and music: the relationship between their respective populations and their respective products (import and export), paying special attention to stimulants and, within these, cocoa, alcohol and iboga, as well as their very different uses, effects and meanings for colonisers and colonised.



15 JUNE (Wednesday)

Lecture

### COCOA, ALCOHOL AND IBOGA

Juan Aranzadi

19:00

📍 Workshop

After a brief presentation on the interrelationship between the different lectures, this introduction will focus on different uses, meanings and anthropological implications of three stimulants in their various comings and goings: cocoa, native and colonial alcohol and, in particular, iboga in the colonial period and the post-colonial globalisation era.

Lecture

### BASQUES IN THE SPANISH COLONISATION OF EQUATORIAL GUINEA

Donato Ndongo Bidyogo

20:00

📍 Workshop

Brief study reflecting on the realities of Spanish colonialism in Equatorial Guinea and its stereotypes, infused in the minds of the natives, subjects of colonialism. An objective, detailed analysis of the historical role of civil and religious characters of Basque descent in the relationships between the mother country and the colony and in forging the national conscience, from the 19th century exploration of Manuel Iradier until the independence of the new country.

16 JUNE (Thursday)

Lecture

### BASQUES IN AFRICA, THE BUBI PEOPLE IN EUROPE AND FATHER SCHMIDT

Juan Aranzadi

12:00

📍 Z Hall

This lecture aims to reflect on the great influence that the anthropological theories of the Vienna School, led by Father Schmidt, have had on the ideological development of Basque ethnicity through father Barandiarán and Bubi ethnicity through father Martín del Molino.

Lecture

### USES AND REDEFINITION OF BIOMEDICAL MEDICATION IN EQUATORIAL GUINEA

Alvar Jones Sánchez

17:00

📍 Z Hall

The use of industrial medicines, biomedical technology icons, is part of the everyday life of most homes in Equatorial Guinea. Their acquisition and administration without the supervision of health professionals is the first and most widespread response mechanism against disease. The use of medication is based on the production and mobilisation of specific knowledge, which takes into account reappropriation and redefinition processes sometimes far removed from the recommendations issued by the official health agencies.

Lecture

### STIMULANTS IN IMAGES: PRODUCING AND REPRODUCING COLONIALISM

Alba Valenciano Mañé

19:00

📍 Z Hall

In this session, a series of images will be shown and there will be a discussion on the role of stimulants in the colony in both its productive (basis of the colonial economy) and reproductive (essential for the reproduction of the colonial social system) dimensions.

17 JUNE (Friday)

Lecture

### COCOA, COFFEE AND WOOD IN THE SPANISH COLONISATION OF EQUATORIAL GUINEA

Gonzalo Álvarez-Chillida

12:00

📍 Z Hall

Coffee, cocoa and wood were the three major production lines in the colony. Cocoa started to be exploited in Fernando Pó from the 1880s, initially by the rich Creoles (from Sierra Leone), who ended up being displaced by Spanish settlers.

Lecture

### SLAVERY AND SLAVE TRAFFICKING IN EQUATORIAL GUINEA

Gustau Nerín

17:00

📍 Z Hall

The societies of what is now Equatorial Guinea remained on the fringes of the Atlantic slave trade for centuries. Finally, between 1785 and 1845 they

were fully involved in it, to the point where some areas of the country suffered a strong demographic impact.

Lecture

### COCOA AND MUSIC IN EQUATORIAL GUINEA

Isabela de Aranzadi

18:00

📍 Z Hall

In emerging urban societies, music fits into the relationships between social sectors, whether linked to ethnic factors, class or origin. The cultivation of cocoa in Fernando Pó during the 19th and 20th centuries brought together African workers (Creoles, Bubis, Africans from the coasts, Krumans, Cubans, etc.) in a confluence of encounters that would lead to exchanges of musical genres such as cumbé, bonkó and maringa.

Programme of activities

### LISTENING OBSERVATORY

Curated by Xabier Erkizia

📍 Z Hall

By formulating the idea of a listening observatory in an almost literal way, this proposal aims to create a space for debate and dialogue about the soundscape. Through the participation of people from diverse places with diverse experiences (art, culture, urbanism, social sciences...), the programme includes discussions, lectures, recitals, hearings and other public activities.

Project in collaboration with DSS2016EU, curated by Xabier Erkizia, Mikel R. Nieto and Jose Luis Espejo.

**8 APRIL** (Friday)

Lecture

**USES AND ABUSES OF WATER**

Peter Cusack

19:00

📍 Z Hall

The project called *Uses of water and soundscapes of its abuses* aims to analyse the effect of the use of water on the environment and human beings. The focus is on places in which the contrasts are exposed between sustainable and unsustainable practices and interdependencies between local, national and global concerns. This project seeks to be a collaboration between different disciplines - sound, journalism, plastic arts, geography, science - and among those participating at different levels is:

**Peter Cusack:** He is a musician and sound artist.

In collaboration with Crista Enea Foundation.

**16 APRIL** (Saturday)

Lecture

**SOUNDS OF THE COUNTRYSIDE AND THE NOISE OF ARTISTS**

Luis Costa

19:00

📍 Z Hall

A critical point of view will be presented, based on the experience of many years organising the landscape and sound (soundscape), with the intention of showing how relationships have been developed with the cultural landscape under research.

**7 MAY** (Saturday)

Conference

**AUGMENTED SPATIALITY**

María Andueza

20:00

📍 Z Hall

«Augmented Spatiality» is the name of a project dedicated to public art, that was held in Stockholm in 2015. The works of art, performances and other activities included in it merge into other spatial processes that tend to occur in the public sphere. The project brings together artists, citizens, institutions and public infrastructures in the same framework, emerging in places where cultural, educational and other economic and political events are held. Topics include critical walks, gentrification processes, ideas on presence and their impact on the soundscape.

**14 MAY** (Saturday)

workshop + concert

Guests: Michael Pisaro, Stéphane Garin, Didier Aschour

20:00

📍 Workshop

Concert programme:  
Hearing metal 4 (birds in space)\_2011  
Grounded cloud\_2015

In his compositions, Michael Pisaro has shown a special sensitivity to the combinations of acoustic instruments, objects and sound textures from *field recordings*. In this lecture, Pisaro will talk about what drove him to carry out research in these fields and the formal results obtained from this research.

**15 MAY** (Sunday)

Workshop + concert

Guest: Michael Pisaro

16.00 - 20.00

📍 Workshop

Taking advantage of the presence of the composer, we will have the chance to work on one of his compositions as a group, live, in this exceptional one-day workshop. To participate, no special knowledge about music is required.

**18 JUNE** (Saturday)

Lecture

**FROM THE SOUND FILE TO THE EVENT**

Xoan Xil

19:00 ES

📍 Z Hall

There are many ways of analysing, representing or acting out the soundscape. Based on a series of examples, the lecture will delve deeper into them.

**3 - 4 JUNE** (Friday-Saturday)

Lecture

**CITY AND OTHER POLICIES V: "THE INSTITUTION AS A CITY"**

Ethel Baraona, Itziar Gonzalez, Miguel Mesa del Castillo, Jule Goikoetxea, Koldo Telleria, Marc Badal and Andoni Egia

Friday: 18:00-20:00

Saturday: 11:00-13:00

📍 Workshop

*City and Other Policies* was born from the need to take a critical look at the production of public space and the

construction of the city, in order to discuss other ways of carrying out and reflecting on spatial practices. In this fifth edition, the city and the region provide us with a sharper image in the form of a reflection on political models and ways of exercising power: They become the best physical mediums for deploying all kinds of governmental and control strategies over the public sphere. If the street, the public space, is already part of the machinery-institution, it is paradoxical that cultural policies which restore buildings for new uses organise their spaces with idea of reproducing a city within its old walls.

The Tabakalera "ecosystem" is hiding all of the complexity and contradictions that a contemporary city projects under its new layers of reformation. The new "ecosystem" is a small city. Take it as being a critical space, as a medium which still has "cracks" on which to work and discuss the management of what has been inherited, its significance and the relationships and/or domination established with and between the recovered areas; and the city.

Theoretical positions and practices from the region, the city, politics and the economy will be exchanged at this open round table coordinated by Ibon Salaberria and Ula Iruretagoiena.



# HIRIKI- LABS

---

**HIRIKILABS. DIGITAL CULTURE AND  
TECHNOLOGY LABORATORY.**

Project created in collaboration between  
Tabakalera and Donostia / San Sebastián  
2016 European Capital of Culture

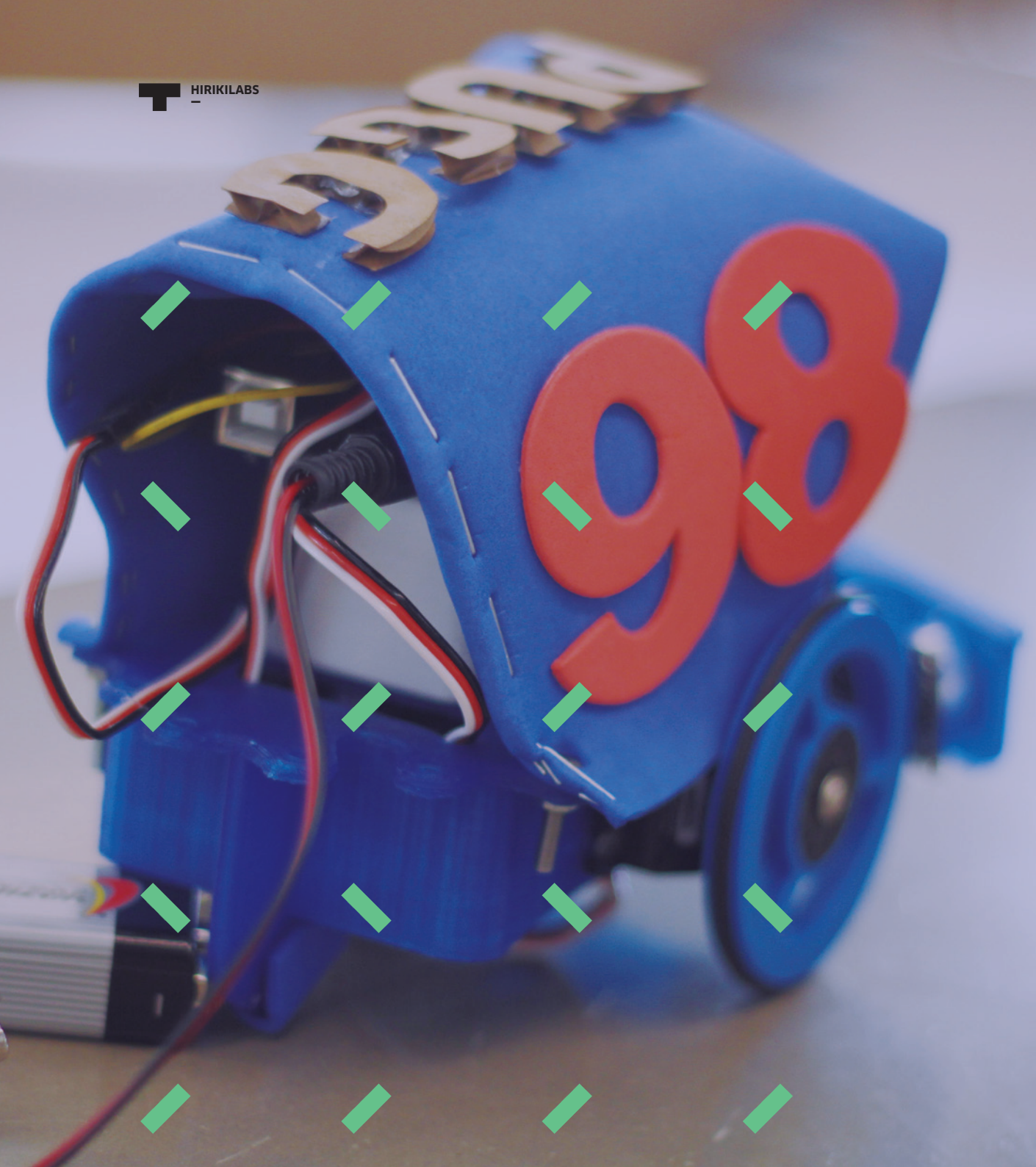

## HIRIKIKAS

**5, 12 APRIL** (Tuesday)

**Workshop**

### HIRIKIKAS, INTRODUCTION TO CNC

**17:00 - 20:00 Basque**

*Collaborators: Joseba Egia*

Registration: [www.tabakalera.eu](http://www.tabakalera.eu) or at the information point

📍 Hirikilabs

Learning session on programming and handling milling machines controlled by computer numerical control (CNC), aimed at carrying out a project. Contents: What is milling? Types of milling machines. Gcode orders. Libraries with digital examples. Vector editing software. Preparation of a file for milling. Milling tests.

**8, 15, 29 APRIL** (Friday)

**11, 13 MAY** (Wednesday and Friday)

**Workshop**

### HIRIKIKAS. TURNING ON THE DARK SPOTS

**17:00 - 20:00 Basque / Spanish**

*Collaborators: Olatu Talka*

Registration: [www.tabakalera.eu](http://www.tabakalera.eu) or at the information point

📍 Hirikilabs

The next edition of the Olatu Talka invites to citizens to intervene at several of the 41 places included in the document Mapa de Puntos Críticos de Donostia - San Sebastián (Map of critical points in Donostia - San Sebastián).

Hirikilabs in collaboration with Olatu Talka, will offer the workshop *Turn on the dark spots*, aimed at the collaborative design and manufacture of a light

installation that must respond to a specific problem by making a creative use of technology.

**26 APRIL; 3 DE MAY** (Tuesday)

**Workshop**

### HIRIKIKAS: 3D SCANNING AND CREATION OF MOULDS

**17:00 - 20:00 Spanish**

*Collaborators: Arquimaña*

Registration: [www.tabakalera.eu](http://www.tabakalera.eu) or at the information point

📍 Hirikilabs

We will learn techniques to design and manufacture moulds, in order to gain the basic knowledge to allow us to realise our ideas.

**27 APRIL** (Wednesday); **18 MAY**

(Wednesday); **8, 17 JUNE**

(Wednesday and Friday)

**Workshop**

### GUIFINET

**17:00 - 20:00 Basque**

**17 JUNE: 16:00 - 19:00 Workshop**

**19:00 Talk (1<sup>st</sup> floor hall)**

*Collaborators: Gisa Elkarte, Ping*

Registration: [www.tabakalera.eu](http://www.tabakalera.eu) or at the information point

📍 Hirikilabs

Guifi.net is a free, open source, neutral telecommunications network. From four open workshops, we will be able to learn how this network and its technology work.

### SEASON. ACCESS TO INFORMATION: NEUTRALITY AND DATA

Continuing the season that began in March, we now focus our attention on open source data.

The concept of open source data is a philosophy and practice that aims for certain types of data to be available free for everyone, without the restrictions of copyright, patents or other control mechanisms.

**19, 20, 21 APRIL** (Tuesday-Thursday)

**Workshop**

### HIRIKIKAS: WORKSHOP ON ANALYSING AND VISUALISING DATA FOR NON-PROGRAMMERS

**17:00 - 20:00 Spanish**

*Collaborators: Oscar Marín + Alejandro González - Outliers.es*

Registration: [www.tabakalera.eu](http://www.tabakalera.eu) or at the information point

📍 Hirikilabs

The aim of the workshop is to introduce the ecosystem of tools for analysing and visualising data. To attend, it is not necessary to have prior programming knowledge.

**MAY** (Date to be confirmed)

**Workshop**

### DATA JOURNALISM, BIG DATA AND CITIZEN ACTIVISM

**17:00 - 20:00 Spanish**

*Collaborators: Miren Gutierrez and Stefania Milan*

Registration: [www.tabakalera.eu](http://www.tabakalera.eu) or at the information point

📍 Hirikilabs

Collecting and analysing large amounts of data by means of specialist software, making the information understandable through computer graphics and data visualisation... and understanding how the management and compression of data is a tool for citizenship is what we will work on in this workshop.

**6 MAY** (Friday)

**Presentation**

### CASEANDO

**19:00 Spanish**

*Collaborators: VIC Vivero de iniciativas ciudadanas*

📍 Hall 1. floor

From May 6, Tabakalera will welcome Caseando, an itinerant project developed by the Vivero de Iniciativas Ciudadanas (Incubator of Citizen Initiatives) and produced by La Casa Encendida, which already has passed through spaces like Intermediae (Matadero) and Etopia (Zaragoza). Hirikilabs will extend the laboratory to the distributor on the first floor, sharing meetings, talks and workshops in this space.

**17 MAY** (Tuesday)

**Workshop**

### HIRIKIKAS: IFTTT + PHOTON

**17:00 - 20:00 Spanish**

*Collaborators: Joseba Egia*

Registration: [www.tabakalera.eu](http://www.tabakalera.eu) or at the information point

📍 Hirikilabs

Using Photon, it is possible to connect to things on the internet and, with IFTTT, it is possible to create connections between applications and things. Together, they open up a multitude of possibilities for our imagination. In this workshop, we will learn to use the two technologies to create projects.

**14, 15 JUNE** (Tuesday and Wednesday)

**Workshop**

### TOOLS TO CREATE SOUND

**17:00 - 20:00 Spanish**

Registration: [www.tabakalera.eu](http://www.tabakalera.eu) or at the information point

📍 Hirikilabs

This workshop is presented as an open space, where attendees will explore the possibilities offered by different software tools in the creation and design of sound and electronic music.

**21, 22 JUNE** (Tuesday and Wednesday)

**Workshop**

### SOUND PROJECT USING OPEN SOURCE HARDWARE

**17:00 - 20:00 Spanish**

Registration: [www.tabakalera.eu](http://www.tabakalera.eu) or at the information point

📍 Hirikilabs

A workshop in which we will develop a sound project from open source hardware.

## JOLABS

**2, 9, 16 APRIL** (Saturdays)

**Workshop for families**

### JOLABS: CREATIVE ELECTRONICS

**11:00 - 13:00 / Age: 5-12 years old**

Registration: [www.tabakalera.eu](http://www.tabakalera.eu) or at the information point

📍 Hirikilabs

How does electricity work? What is electronics? We will learn the basic concepts on these subjects and, using creativity, we will undertake small projects: we will design toys with electric circuits, play video games using electronic boards...

**23, 30 APRIL; 7 MAY** (Saturdays)

**Workshop for families**

### JOLABS: SCRATCH

**11:00 - 13:00 / Age: 5-12 years old**

Registration: [www.tabakalera.eu](http://www.tabakalera.eu) or at the information point

📍 Hirikilabs

Scratch is a language for programming video games in a simple manner. To warm up for Scratch Day, which we will hold at Tabakalera on May 14, on the preceding Saturdays we will look at the basics of Scratch. We will learn how it is used and what possibilities it gives us and we will create various video games.

**28 MAY, 4 JUNE** (Saturdays)

**Workshop for families**

### JOLABS: DIGITAL PUPPETS

**11:00 - 13:00 / Age: 7-14 years old**

Registration: [www.tabakalera.eu](http://www.tabakalera.eu) or at the information point

📍 Hirikilabs

We are going to bring together digital content and the movement of our body using sensors, thus creating interactive digital puppets.

**11, 18 JUNE** (Saturdays)

**Workshop for families**

### JOLABS: SOUND

**11:00 - 13:00 / Edad: 7-14 años**

Registration: [www.tabakalera.eu](http://www.tabakalera.eu) or at the information point

📍 Hirikilabs

Throughout June, in different workshops, we will enter the world of sound. Using electronics, toys and items that we have at home, we will create musical instruments.

**24, 25 JUNE** (Friday and Saturday)

**Workshop for families**

### JOLABS: HANDMADE ELECTRONIC MUSIC

**24 JUNE, 17:00 - 20:00**

**25 JUNE, 11:00 - 13:00**

**Age: + 7 years**

*Guest: Mateo Mena*

Registration: [www.tabakalera.eu](http://www.tabakalera.eu) or at the information point

📍 Hirikilabs

Electronic music is not confined to computers, it can also be made physically. This workshop will help us to learn how to create the basic components required to make electronic music with our own hands: resistors, capacitors, transistors, batteries and speakers.

## OPEN GROUPS

**APRIL, MAY, JUNE**

(Every Thursday)

**Open group**

### GUIFI.NET MOBILE NODE DESIGN GROUP

*Collaborators: GISA*

**16:00 - 20:00**

📍 Hirikilabs

Guifi.NET is an initiative to build an open, free, neutral telecommunications network. The group, which will meet at Hirikilabs, will aim to design an open mobile node developed by the Guifinet group in Egia and San Sebastián.

**APRIL, MAY, JUNE**

(Every Thursday)

**Open group**

### OPEN DESIGN

**16:00 - 20:00**

📍 Hirikilabs

This group gets together with the idea of investigating the possibilities of digital creation and manufacturing

**APRIL, MAY, JUNE**

**Open group**

### STEAM OPEN GROUP. LABORATORIES IN THE FIELD OF EDUCATION

📍 Hirikilabs

In recent years different teachers and self-managed and self-taught educational centres have created real open labs for students, where the first thing was the development and empowerment of people with technology as a means. This open group was created to share and make these best practice visible so that they serve as an alternative to all those centres that think about creating lab linked to developing technological projects.

**6 APRIL** (Wednesday)

**Meeting**

### HOW WOULD YOU BRING GENDER AND TECHNOLOGY TOGETHER IN EDUCATION? IN SEARCH OF A PRACTICAL PROPOSAL

**18:00 - 20:00 Basque**

*Collaborators: Danel Solabarrieta*

Registration: [www.tabakalera.eu](http://www.tabakalera.eu) or at the information point.

📍 Hirikilabs

This meeting will be a space for debating gender and technology. Aside from raising awareness and reflection,

we will work on practical proposals. In addition, there will be presentations on resources for teachers and technology watchers.

**1 JUNE** (Wednesday)

Meeting

**STEM TO STEAM**

**18.00 - 20.00 Spanish**

*Collaborators: Paola Guimerans*

Registration: [www.tabakalera.eu](http://www.tabakalera.eu) or at the information point

📍 Hirikilabs

The workshop aims to show new models of educational research, which already provide for the progressive integration of the arts into the framework of scientific disciplines.

## MEETINGS

**13 APRIL** (Wednesday)

Meeting

**ACCESS CLINIC IREKIA: "INCORPORATION OF CITIZENSHIP WITH FUNCTIONAL DIVERSITY IN PARTICIPATION "ONLINE"**

**10:00**

*Collaborators: Office of Open Government of the Presidency of the Basque Government*

Registration: [www.tabakalera.eu](http://www.tabakalera.eu) or at the information point

📍 Hirikilabs

The arrival of information technologies in the field of functional diversity has brought obvious improvements with it, but it still leaves many doubts. The reality of accessibility to the Internet shows that there is still a way to go.

The Office of Open Government of the Presidency of the Basque Government,

aware of the need to get the content which is published on the Irekia website to all citizens, proposed this meeting at Hirikilabs to test three application prototypes that allow greater access to the web.

**11, 12, 13 MAY** (Wednesday-Friday)

Meeting

**OSLE / / EUROPEAN MEETING OF OPEN SPACE LEARNING EXCHANGE.**

*Collaborators: Gune Irekien Lagunak*

Registration: [www.tabakalera.eu](http://www.tabakalera.eu) or at the information point.

📍 Z Hall

Meeting on the Open Space methodology to work on how to evolve and extend this technique.

**14 MAY** (Saturday)

Meeting

**SCRATCH DAY**

📍 Tabakalera

Scratch Day is a network of events held around the world. School students will show their projects made with Scratch and there will be various workshops to learn and have fun with this programming language.

**21 MAY** (Saturday)

Meeting

**OLATU TALKA**

Like every year, Hirikilabs will join Olatu Talka, this year with three different activities:

**URBAN ZIENTZIA (URBAN SCIENCE)**

The Calle Iztueta and Plaza Teresa de Calcuta area, between Gros and Egia, will host the first Urbanzientzia meeting. This is a meeting which will

address the dissemination of science in a space away from the academic environment, from a pleasant and accessible perspective for citizenship. Throughout the day, presentations, exhibitions, workshops and laboratories, in which Hirikilabs will also participate, will be combined for both children and adults

**TURN ON THE DARK SPOTS INSTALLATION**

At the end of the conference, the installation built at Hirikilabs will be illuminated.

**MAPPING COLLECTIVE**

An event where anyone without prior knowledge can create a composition of light from the video-mapping technique. Everyone together will make a collective composition.

📍 Square

**10 JUNE** (Friday)

Meeting

**HOW TO MAKE 10**

**18:30**

📍 1<sup>st</sup> floor hall

*How To Make* is a monthly meeting of copywriters, architects, engineers, scientists and members of the general public interested in the maker culture and in learning and sharing. Through a series of talks, Hirikilabs becomes a space for training and theoretical-critical reflection on culture, creation and digital manufacturing. We use the term 'artisans' to define the community or group of people at Hirikilabs who research and share the possibilities of digital technology applied to different fields of interest or work in a traditional way. The themes to be discussed in this session will be DIY Astronomy.

## PLAZA

(Every Thursday)

**OPEN WORK SESSIONS FOR THE PROJECTS IN PROGRESS FOR THE 5TH CALL**

**16:00 - 20:00**

📍 Hirikilabs

Hirikilabs Plaza is a space for meeting and developing projects that are constructed from the interaction between people, groups and communities well-versed in the field. From February 2016 to July 2016 they will be working at Hirikilabs on projects for the 5th Plaza call.

**10 JUNE** (Friday)

Call

**HIRIKILABS PLAZA: 6TH CALL FOR OPEN PROJECTS**

Website. From June 6 to September 8  
Registration: [www.tabakalera.eu](http://www.tabakalera.eu)

The Hirikilabs-Plaza call for open projects is a process whereby anyone can propose projects related to technology and/or digital culture for their development at Hirikilabs along with other people. The philosophy of this call is to promote free culture, open design and knowledge-sharing. Find out more and present your project on the Tabakalera website.

# EDUCA- TION



**KAMALEOIAK GARA!**

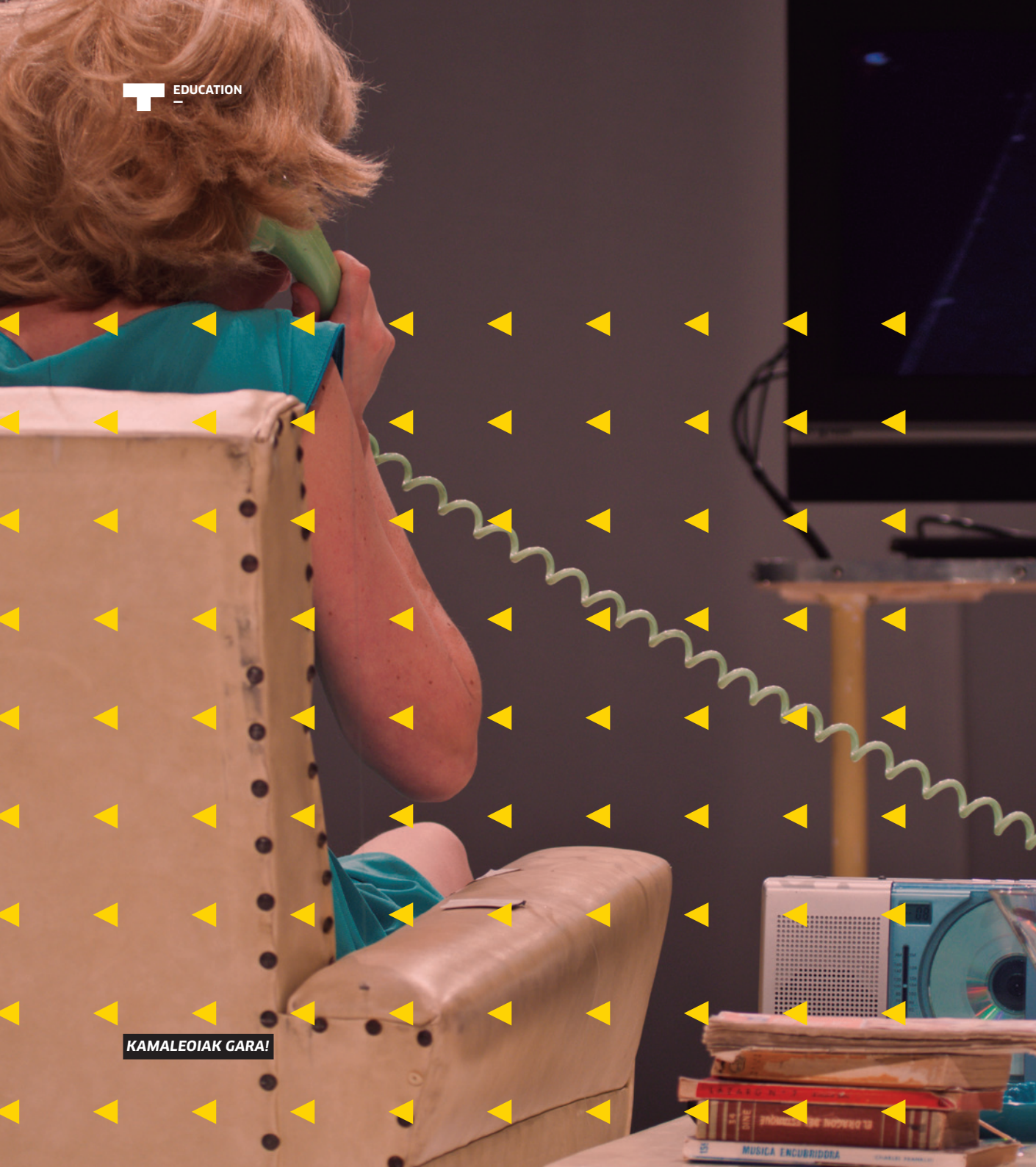

From Wednesday to Friday

Workshop for groups

**PASEOS - WORKSHOP**

10:00 - 14:00 / 16:00 - 20:00

Registration: [www.tabakalera.eu](http://www.tabakalera.eu)

943 011 311

For: Educational centres and associations.

The workshop-walks are a way of learning more about Tabakalera and involve the possibility of working with thematic areas related to the architectural space, exhibitions, laboratories and cinema. They are dynamic sessions in which we adapt to the groups' needs and interests and seek their active participation. Thus, different learning situations are created with moments of dialogue, practical research and games.

Workshop for groups

**3+1 MID-TERM PROGRAMMES**

Dates: To be agreed with the group organiser. Times: To be agreed with the group organiser. Duration: Four work sessions. The duration of the visits to Tabakalera will be 2 hours, while the work in the classroom will be adapted to the times needed by each group.

Registration: [www.tabakalera.eu](http://www.tabakalera.eu) 943 011 311. For: Education centres and associations in the area of Donostialdea.

Mid-term programmes are designed for schools that want to work in collaboration with the Tabakalera mediation team in a long-term relationship. Direct experience with artistic and cultural practices (exhibitions, cinema, music, performing arts, etc.) will serve as a starting point for working with groups based on their needs and interests.

\* There is an option to take part in THE NAMES WORKSHOP. + Info on the exhibition section.

2, 9, 16, 23, 30 APRIL  
7, 14, 21 (ILSE) and 28 MAY

4, 11, 18 and 25 JUNE  
(Saturdays)

Visit

**VISIT TABAKALERA**

11:00-12:00 (Basque)

12:00-13:00 (Spanish)

📍 Info point

Registration: [www.tabakalera.eu](http://www.tabakalera.eu) or at the information point

Tours on the history and cultural project of Tabakalera

24 APRIL; 29 MAY; 26 JUNE (Sundays)

Cinema

**ZOOM+ERA ATÓMICA**

18:00

📍 Cinema

Screening put on by the group ZOOM. Video Laboratory activated by the Tabakalera mediation area and the Institute of Secondary School Usandizaga. This quarter, we will choose programming together with young people from the SUB-21 Dos de Mayo Art Centre team (Móstoles).



Visit to the exhibition ARENZANA IMAZ INTXAUSTI MONTÓN PERAL

25 MAY (Wednesday)

Conversation

**SPACE 0-6. RETHINKING THE PLAY SPACES**

Guests: Ttipi studio (Ane Abarrategi and Maddi Texeiro), Iñaki Larrea (Mondragón University, HUHEZI). Presentation of the Elkartoki project.

17:00 Basque

📍 Workshop

At Tabakalera we began a process of reflection regarding the spaces where children between the ages of 0 and 6 and adults co-habit and reflect on education and upbringing. These resources will be designed and built collaboratively in the Hirikilabs laboratories. The construction process will be accompanied by public meetings to reflect on various issues relating to education between the ages of 0 and 6. The first open session will be in May. To take part in the process, please write to [hezkontza@tabakalera.eu](mailto:hezkontza@tabakalera.eu).

3 JUNE (Friday)

Opening ceremony

**IKASTOLARIK AUZORA! LAUNCH OF THE PASSAGEWAY**

17:00

📍 Jakintza Ikastola, Heriz pasealekua 109 (Antiguo)

The long-term call for projects "City, Education and Collaborative Practices" began last September, with the launch of the project presented by Jakintza Ikastola. Throughout the school year, in order to strengthen ties with the school and the neighbourhood, we are collectively reactivating a passageway, which will become a place for cultural exchange. This space will be inaugurated on June 3, where the project process will be shared.

## KAMALEOIAK GARA!

Kamaleoiak Gara! is a programme of activities open to young children accompanied by an adult. Mothers with sons, fathers with nieces, grandmothers with grandchildren ... a place to be in Tabakalera together, sharing knowledge and learning from a community made up of people of very different ages.

**17 APRIL; 15 MAY** (Saturdays)

**Workshop**

### KAMALEOIAK GARA! WORKSHOP

**11:00 Basque**

📍 Education room

Workshop for children and adults. We will be taking a close look at the exhibition "The Day After" by Maryam Jafri, elaborating on themes such as memories, archives and the body.

**28 MAY; 11 JUNE** (Saturdays)

**Workshop**

### KAMALEOIAK GARA! BIZIGARRIAK

WHERE DOES YOUR BREAKFAST COME FROM?

**11:00-13:00 Basque**

📍 Education room

The education department is adding to the project Stimulants: Traffic and Euphoria with a workshop entitled Where does your breakfast come from?. Throughout 2016, the Kamaleoiak gara! workshops will focus on addressing the origins, production processes and possible transformations of the food we normally eat.

**28 May:** Where does chocolate come from?

**11 June:** Jelly mini-cups

**24 APRIL; 5 JUNE** (Sundays)

**Cinema + Workshop**

### KAMALEOIAK GARA! CINEMA

**12:00 EU**

Registration: [www.tabakalera.eu](http://www.tabakalera.eu) or at the information point

📍 Cinema

A new format will be added to the Kamaleoiak gara! programme from April onwards. Once a month, the Tabakalera cinema will present an audiovisual programme for all ages (animation, experimental cinema, short films...). After the screening, we will conduct a workshop to work collectively on issues and techniques related to the film.

**23 APRIL** (Saturday)

**Performance art**

### KAMALEOIAK GARA! PROGRAMME

#### THE CASE OF THE SPECTATOR

*Guest: María Jerez*

**17:00 ES (45') Age: + 7 years**

Registration: [www.tabakalera.eu](http://www.tabakalera.eu) or at the information point.

📍 Z Hall

A few books, a television, a camera and an armchair with its back to the audience. A woman sets this mechanism in motion and, by doing so, creates a live film of which she herself is a spectator. The spectator watches a watched spectator who watches. Through the use of the camera, there are two realities taking place simultaneously, with a live situation and a film scene unfolding thus.

**14 MAY** (Saturday)

**Shadow theatre**

### KAMALEOIAK GARA! PROGRAMME

#### DO NOT TOUCH MY HANDS

*Guest: Compañía Valeria Guglietti*

**17:00 (45') no dialogue**

Registration: [www.tabakalera.eu](http://www.tabakalera.eu) or at the information point

📍 Z Hall

Chinese shadows meet silent films, puppets, comics and music to create a myriad of stories that will transport us to other worlds.

**18 JUNE** (Saturday)

**Workshop + Show**

### KAMALEOIAK GARA! PROGRAMME REZIKLANTES

*Guests: Compañía Turukutupa (Sergio López de Landache and Víctor García de la Torre)*

**16:00 Workshop Basque**

**17:00 Show (40')**

Registration: [www.tabakalera.eu](http://www.tabakalera.eu) or at the information point.

📍 Z Hall

On this occasion, we present a workshop-concert, where attendees will build musical instruments with waste to later take part in a concert, where we will take a tour of different musical styles, such as African and Latin percussion, hip-hop and contemporary music.



NO TOQUEN MIS MANOS, Compañía Valeria Guglietti

# UBIK

---



**Ubik. Opening hours:**  
Tuesday to Saturday: 12:00 - 14:00, 16:00 - 20:00  
Sundays and holidays: 10:00 - 14:00



APRIL, MAY, JUNE

Monthly meeting

**SOINUTEGIA**

18:00-20:00

Led by: *Xabier Erkizia*

Ubik

Soinutegia is an attic. More than a storage space, a cache. More than a music library, a sound library. Without the need to have to make distinctions between all forms that sounds can take, this space aims to be a showcase for music, noises, voices and pure frequencies equally. Archives, collections, records, discographies, cassettes, testimonies, tones, inharmonies and other audio matter can be heard. We could call it an auditorium without an audience or a concert without a stage, but we could also call it a private concert hall or showcase for sound recordings. Just as there are the viewing points and observatories, we should also be able to build listening spaces. In short, Soinutegia is a place where not listening is prohibited.

APRIL, MAY, JUNE (Every Wednesday)

Weekly workshop

**WEDNESDAY EN UBIK**

17:30-19:00 / Age: 6-10 years old

Registration: [www.tabakalera.eu](http://www.tabakalera.eu)

Ubik, Workshop

Every Wednesday we will hold workshops that stimulate topics of Ubik, creation library of Tabakalera. Aimed at children, it will boost creation and be time spent in a fun way.

8 APRIL; 13 MAY; 10 JUNE (Fridays)

Monthly workshop

**NELL'S SCHOOL. TRAINING WORKSHOP ON MANAGING TECHNOLOGIES AND THE INTERNET**

18:00-20:00 Basque

Led by: *Gorka Julio*

Registration: [www.tabakalera.eu](http://www.tabakalera.eu)

Ubik, Workshop

Nell is the name of the main character in the Neal Stephenson novel "The Diamond Age". In the book, Nell gets an advanced, intelligent electronic book that helps you to learn on your own. Thanks to this book, she gets training and design her own path.

In this school, which continues in the spirit of Nell, through workshops, we are looking for training on the use of technologies and the internet. By means of theoretical-practical-participatory workshops, every month we will deal with a subject:

April: Information management

May: Managing social networks

June: Security on mobile devices

9 APRIL; 14 MAY; 11 JUNE (Saturdays)

Workshop

**HORKONPON. REPAIR WORKSHOP**

10:00-14:00

Ubik, Workshop

The aim of the *HorKonpon* workshop is to help make citizens more independent (*do it yourself*) and share their knowledge. It centres around the repair and re-use of tools we use in our everyday life and encourages team work (*do it together*). Bring your broken gadgets and devices and repair them with us!

This activity is being organised in collaboration with DSS2016EU.

12, 26 APRIL; 10, 24 MAY; 14, 28 JUNE

(Tuesdays)

Meeting

**I ALSO WANT!**

11:00-12:30 / Age: + 50 years

Registration: [www.tabakalera.eu](http://www.tabakalera.eu) or at the information point

Ubik, Video games corner

Who said that video games were for young people? There are no age limits for playing, trying, testing and enjoying. Come and discover the world of video games!

15 - 17 APRIL (Friday-Sunday)

Presentation

**LOAD"" HISTORY OF BASQUE VIDEO GAMING (1985-2009). PRESENTATION OF CHAPTERS 6 AND 7**

18:30-20:00

Gipuzkoa Encounter

To show the essential role of the different "parties" in the production and the development of the video game in the Basque country, the writer Julen Zaballa will present in Gipuzkoa Encounter the chapters 6 and 7 of *LOAD"" History of Basque video gaming (1985-2009)*.

14 APRIL; 12 MAY; 9 DE JUNE (Thursdays)

Presentation

**NODES. STIMULANTS: TRAFFIC AND EUPHORIA**

*Ion Munduate, German Sigwald, Cristina Camara*

Ubik

In connection with the project *Stimulants: traffic and euphoria*, that the Tabakalera area of artistic projects launched and

which deals with various aspects of modern stimulants such as coffee, sugar, tobacco and cocoa from different perspectives, Ubik proposes Nodes, a programme that invites different professionals to choose five documents that are part of the resources of the creation library. The guests will make a public presentation, arguing the path that they have taken.

Guests:

April 14: *Ion Munduate*. Artist

May 12: *German Sigwald*. Writer

June 9: *Cristina Camara*. Curator of film and video.

15 APRIL; 20 MAY; 17 JUNE (Fridays)

Monthly meeting

**VIDEO KILLED THE RADIO STAR**

17:00-19:00 Basque + Spanish

Age: + 16 years

Guest: *Itziar Orbegoza*

Registration: [www.tabakalera.eu](http://www.tabakalera.eu) or at the information point

Ubik

Since MTV broadcast the first video clip in 1981, we have been able to see different songs, creators, directors, techniques and formats. We can relive different moments of our life through these films: classics, contemporary, in black and white, pioneers, analogue, digital, experimental, modest... All styles fit in these small audiovisual works.

Do you like video clips? If you want to watch, enjoy, analyse, and experiment, this is the place for you! Let's get rocked!

**17 - 22 APRIL** (Sunday-Friday)

**Workshop**

**INTERNATIONAL YOUTH MEETING ON CINEMA AND HUMAN RIGHTS**

📍 Ubik

This meeting seeks to promote reflection on the violation of human rights and the potential of visual arts to promote the guarantee that they can be exercised. The working group will be made up of 33 students and young professionals who are training in the field of human rights or cinema; 10 are Basque, 19 come from Europe and 4 from Western Sahara. For six days, participants will work at Ubik to develop an audiovisual piece that will address a topic related to human rights. In the process, they will have the help of facilitators in the area of cinema and human rights.

This initiative is organised by the San Sebastian Human Rights Film Festival and DSS2016EU.

**19 APRIL; 17 MAY; 21 JUNE** (Tuesdays)

**Monthly meeting**

**EXPERIMENTAL SCREEN**

**18:30-20:00 Basque + Spanish**

**Age: + 16 years**

*Led by: Aitor Gametxo*

Registration: [www.tabakalera.eu](http://www.tabakalera.eu) or at the information point

📍 Ubik, Experimental screen

“Experimental film brings together some of the most varied film making practices under this threatening term. Despite the differences, the exaltation of form, remoteness from the commercial circuit, its experimental nature and rejection of conventional narrative are, among others, some of the features that films that are

considered experimental share. In this way, experimental cinema, as a practice for expressing ideas and bringing experiences together, defines itself by what it is not, i.e. by being something other than mainstream cinema. But the existence of this type of conventional cinema, omnipresent and omnipotent, beyond detracting from experimental practice, praises and gives it meaning.

*Experimental Screen* is a meeting point for these particular views, with the intention of bringing the public closer to this type of material. A way, not just to understand but to experience experimental cinema”.

**21 APRIL** (Thursday)

**Presentation**

**UBIK BISITARIAK. EUSKAL HARRIAREN ABD-AK**

**19:00-20:00 Basque**

📍 Ubik, Experimental screen

*Euskal Harriaren ABDak* is a film collective made up of scary, science fiction and fantasy short films created by 26 directors from the Basque Country. In the summer of 2014, each of them was assigned one of the 26 letters of the Basque alphabet and starting with that letter, they were asked to create a short film. Film makers from the 7 provinces, each working on their own, created a film made up of 26 short films. The only conditions were: to record in Basque, to base them on Basque elements and to produce them entirely in the Basque Country.

At Ubik, a selection of these films will be shown and we could converse with some of the film makers.

**23 APRIL** (Saturday)

**Intervention**

**BOOKCROSSING**

**All day**

📍 Tabakalera

Like every year, we celebrate Book Day with a BookCrossing. Come to Tabakalera and find books. You will get a surprise when you find people hiding behind “freed” books!

**24 APRIL; 29 MAY; 26 JUNE**

(Sundays)

**Monthly meeting**

**SALTO. FAMILY CONVERSATIONS**

**11:30-13:00 / Age: +6 and adults**

*Guests: Ainhoa Artxanko, Amaia Urzain*

Registration: [www.tabakalera.eu](http://www.tabakalera.eu) or at the information point

📍 Ubik

We will share family moments to do, talk about, listen, create and, therefore, think about topical issues. We will activate the monthly meeting Salto to explore and discover the different resources that the Ubik creation library offers us.

**27 APRIL** (Wednesday)

**Meeting**

**ATLAS. KNOWING THE CONDITIONS FOR BEING IN LIBRARIES**

**18:30-20:00 Spanish**

*Guest: Garikoitz Fraga, Belleza Infinita argitaletxea*

📍 Ubik, Desktop publishing corner

In the april sessions, the aim will be to clarify doubts about what selling self-published works involves: delivery notes, invoices, stock control, relationships with

bookshops, exhibition modes ... To do this, we will have Garikoitz Fraga from the publishing house Belleza Infinita, who will share his experience and advice.

**30 APRIL; 28 MAY; 25 JUNE** (Saturdays)

**Monthly meeting**

**OUTLINE. CRITICAL THINKING**

**11:30-13:30 / Age: +15 years**

*Guest: Martxel Mariskal*

Registration: [www.tabakalera.eu](http://www.tabakalera.eu) or at the information point

📍 Ubik, Living Room

“Post-modern man moves in a schizophrenic dance, although often not aware of it, although often not wanting to be aware of it: What is real? Where is privacy? Where is power? Who defines our tastes? Is our identity at risk? Can we handle such complexity? ... Schizophrenia and tiredness, but huge smiles. Every man for himself! STOP”.

**14 MAY** (Saturday)

**Presentation**

**SCRATCH DAY. PRESENTATION OF VIDEO GAMES MADE AT UBIK**

**12:00-14:00 Basque + Spanish**

📍 Ubik, Video Games Corner

Ubik joins the celebrations for scratch day. We will present video games created by a group of young people in the Ubik workshop in March and also have the opportunity to play with them.

19 MAY (Thursday)

Presentation

**UBIK BISITARIAK. OKELA SORMEN LANTEGIA**

19:00-20:00 Basque

📍 Ubik

With the intention of giving visibility to special, independent projects, at Ubik we will have presentations on external projects. This time we are inviting members of Okela, a creation laboratory, which is doing a mapping of artists in the Basque Country, to present their work and projects to us as *Artisten Meeting Pointa* among others.

25 MAY (Wednesday)

Meeting

**ATLAS. HAPPYENDING STUDIO, GETTING TO KNOW DESIGN RESOURCES**

18:30-20:00 Spanish

Invitado: *Happyending Studio*

📍 Ubik, Desktop Publishing Corner

Papers, textures, prints, inks, types of binding... everything counts when finishing a publication. Creating a perfect balance between content and form, we will make our desktop publishing be more complete and reflect all of the ideas and objectives we have set. When materials strengthen the message.

1 JUNE (Wednesday)

Presentation

**LOAD"" HISTORY OF BASQUE VIDEO GAMING (1985-2009). PRESENTATION OF CHAPTERS 8 AND 9**

Guest: *Jose María Martínez Burgos "Hafo"*

18:30-20:00 Spanish

📍 Ubik

The role of the company was instrumental in the creation of video games developed in the Basque Country. To learn more about the work that they carried out between 1985 and 2009 and to discuss the evolution of video game companies in the Basque Country, we will have a lecture by the director of Animatu, Jose Maria Martinez Burgos "Hafo". Knowing first hand the context and development, we will present the contents of Chapters 8 and 9 of LOAD"" History of Basque video gaming (1985-2009).

29 JUNE (Wednesday)

Meeting

**ATLAS. GETTING TO KNOW THE COLLECTION OF GABRIELA CENDOYA**

18:30-20:00

📍 Ubik, Desktop publishing corner

What is the motivation behind a collection? At what moment is one aware that all of those books acquired are starting to take shape and create something greater? How do I manage, sort and, above all, show it?

In addition to discussing these issues, we will have the pleasure of enjoying some of the desktop publishing from the collection of Gabriela Cendoya.

30 JUNE (Thursday)

Presentation

**UBIK BISITARIAK. JON URIARTE. LIBRO EN BRUTO + WHP**

19:00-20:00

📍 Ubik

Courtesy of Jon Uriarte, photographer and photography teacher, we will receive a presentation on his publications *Libro en Bruto y WHP* (Unedited Book and WHP).

*Libro en Bruto* is a self-published work in which Uriarte brings together articles on the *En bruto: blog sobre fotografía* (Unedited: blog about photography). In addition to his words, those of a further 32 authors are included, among which we should mention Ignasi López, Julián Barón, Olmo González and Manuel Rivas. Rivas.

*WHP* is the result of a collective work. This publication includes conversations and exchanges of opinions on the photography of Jon Uriarte, Alberto Feijóo, Erik von Frankenberg y Carlos Chavarria.

An interesting session to chat about photography and desktop publishing.



Salto. Familia eleketak

# ARTIST'S SPACE



**20 - 24 JUNE** (Monday - Friday)

**Workshop**

## CURATING PROGRAMME: CURATING PROJECTS

**10:00 - 13:00 y 16:00 - 19:00**

Registration: [www.tabakalera.eu](http://www.tabakalera.eu), selection by open call

📍 Workshop

The relationship between curator and artist is full of nuances and meanings. This first module seeks to complicate and qualify these issues in theory and in practice, enabling a productive look at the work that the curators and artists are doing jointly. We will explore the notion of the curatorial as a theoretical body, while intertwining it with the praxis in specific examples. The module will include theory sessions, screenings of films, a visit to an exhibition and sessions with relevant persons invited to chip in.

Coordinated by Catalina Lozano, it will have the collaboration of Michele Horrigan and Sean Lynch, artists and curators responsible for Askeaton Contemporary Arts in Ireland.

At the Artists' Space, last year we started the curating programme, a line of work dedicated to studying and reflecting on curatorial practices, as well as those matters which transversally and tangentially establish contact with these: criticism, research, production and mediation. This programme is aimed at local, national and international people who intend to dedicate themselves professionally to curatorial practice.

**25 MAY** (Wednesday)

**Conversation**

## CONVERSATION BETWEEN CURATOS

*Catalina Lozano, Tamara Díaz Bringas, Sabel Gavaldón, Aimar Arriola*  
📍 Workshop

*Komisario Berriak* is an initiative of DSS2016EU that supports the training of new curators, with the ultimate aim of producing a curatorial project. Tabakalera will host the first of three laboratories and we will take advantage of this to make available to the public a conversation between the curators of this programme, Tamara Díaz Bringas, Sabel Gavaldón and Aimar Arriola, with Catalina Lozano, an independent curator and coordinator of the first session of our curating programme, to discuss different points of view.

## ARTISTS IN RESIDENCE

During April and June, we will have the following cultural agents in residence:

*Pablo la Parra, researcher.*

He was selected in the joint research residency call launched by Tabakalera and DSS2016EU. His *Europe, future past* project explores transfers between the militant film archive and contemporary visual and artistic practices. During his stay, he will delve deeper into his research and organise a series of activities to make the project visible. More information p.18 (cinema).

*Fran Meana, artist.*

**The history of the Laboratory of Forms.** The project aims to recover and revive the legacy of Isaac Díaz Pardo's Laboratory of Forms, taking the book "Discusión sobre la organización de las Industrias Manufactureras" (Discussion on the organisation of manufacturing industries) as a starting point. Published in 1960 by Díaz Pardo, the book analyses the social and political dimension of his artistic output and explores the connections between art and work.

*Harvey Martínez, artist.*

The project *La ciudad dispersa* (City sprawl) is part of El milagro (The miracle), a multidisciplinary project where, in this case, the first job is to research and document the footprint of *Developmentalism* in San Sebastian, undertake a publication/test and, at the same time, a group of sculptures / installation referring to the developmentalist footprint in Gipuzkoa.



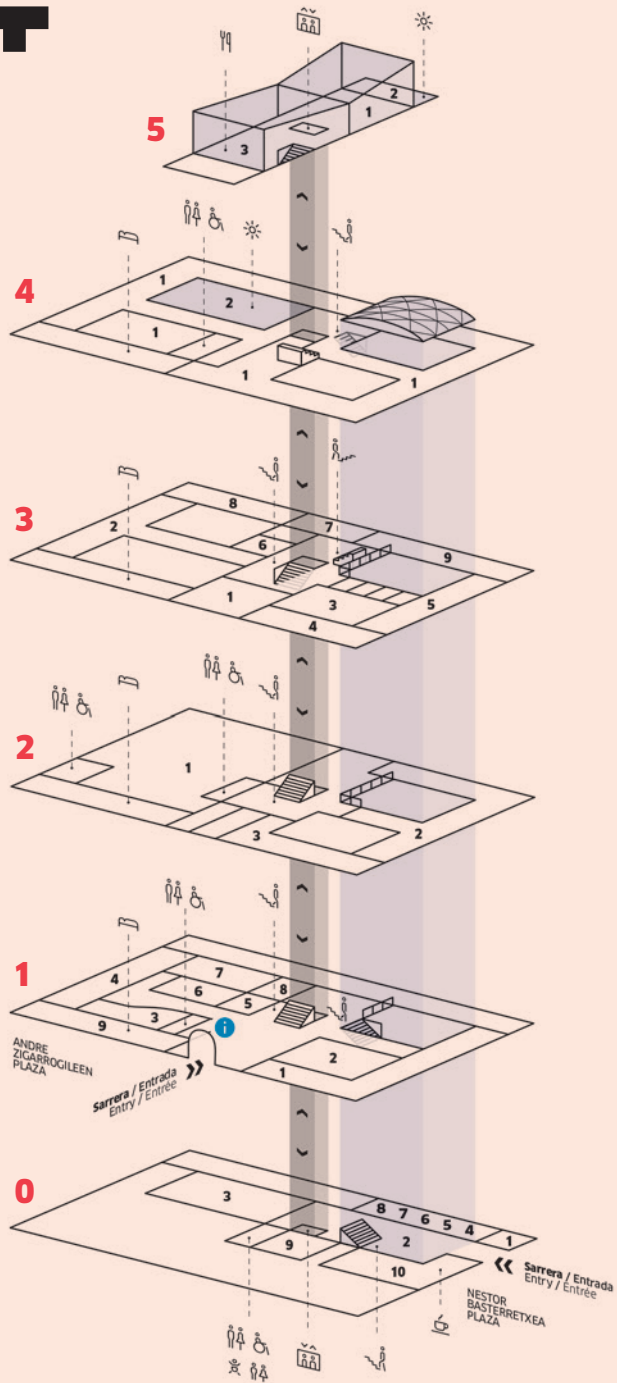

**i**  
Info point

**Lifts**

**WC**

**Changing Table**

**Stairs**

**KUPULA Restaurant**

**TABA**

**Hotel-Residence**

+info  
[www.tabakalera.eu](http://www.tabakalera.eu)

**FLOOR**

**0**

- 1 STORAGE
- 2 SQUARE
- 3 KUTXA KULTUR ARTEGUEA
- 4 NANA
- 5 LÄNTOKI
- 6 ARTEUPARTE
- 7 NON GALLERY
- 8 EL SEKADERO
- 9 KABIAGUNEA
- 10 TABA

**3**

- 1 TABAKALERA'S OFFICE
- 2 HIRIKILABS
- 3 WORKSHOP
- 4 PRODUCTION
- 5 STUDIOS
- 6 K HALL
- 7 ZINEUSKADI
- 8 ETXEPARE BASQUE INSTITUTE
- 9 IMPACT HUB DONOSTIA

**1**

- 1 TABAKALERA'S EXHIBITION HALL
- 2 PATIO
- 3 CINEMA
- 4 Z HALL
- 5 EDUCATION ROOM
- 6 KUTXA KULTUR KLUBA
- 7 KUTXA KULTUR ARTEGUEA
- 8 MISCELANEA
- 9 HOTEL-RESIDENCE  
Opening Soon

**4**

- 1 KUTXA KULTURGUNEA
- 2 ATTIC

**2**

- 1 UBIK  
Tabakalera's Creation Library
- 2 SAN SEBASTIAN INTERNATIONAL FESTIVAL
- 3 BASQUE FILM ARCHIVE

**5**

- 1 PRISMA
- 2 TERRACE
- 3 KUPULA Restaurant

Tabakalera is a free access public space for enjoying contemporary culture. Option of getting the Tabakalera's user card in Ubik.

**TABAKALERA**



**INTERNATIONAL  
CENTRE FOR  
CONTEMPORARY  
CULTURE**

---

**Centre opening hours.**

Monday to Thursday:  
**08:00 - 22:00**

Friday:  
**08:00 - 23:00**

Saturday:  
**10:00 - 23:00**

Sundays and holidays:  
**10:00 - 22:00**

**UBIK.  
Creation Library.**

**Opening hours.**

Tuesday to Saturday:  
**10:00 - 14:00, 16:00 - 20:00**

Sundays and holidays:  
**10:00 - 14:00**

**+Info**  
info@tabakalera.eu  
943 11 88 55

Andre zigarrogileen plaza 1,  
20012 Donostia / San Sebastián  
Gipuzkoa

**tabakalera.eu**

---



Gipuzkoako Foru Aldundia



Donostiako Udala  
Ayuntamiento de San Sebastián



DSS2016.EU