

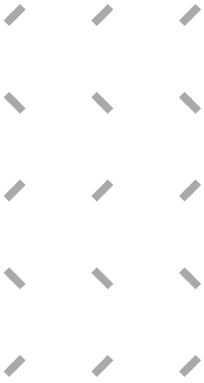

2016



OCTOBER
NOVEMBER
DECEMBER

TABAKALERA



INTERNATIONAL
CENTRE FOR
CONTEMPORARY
CULTURE

OCTOBER
NOVEMBER
DECEMBER





INDEX

12. EXHIBITIONS

22. CINEMA

32. PUBLIC
PROGRAMMES

42. HIRIKILABS

48. EDUCATION

56. UBIK. Creation
Library

66. ARTIST'S
SPACE

70. NOTES

INTRODUCTION

The anniversary has come and gone and the last quarter of the year has somehow crept up on us. Just like autumn colours, Tabakalera will be very colourful during this period of the year. The programme is packed and, while we have taken special care with it, we cannot wait to share it with you.

Autumn will see the first Tabakalera **International Film Seminar** featuring a series of filmmakers and artists who will spend three days with us at the Tabakalera screening room. You will also be able to see 10 films entered in the **Zabaltegi-Tabakalera** section of the Film Festival, an unrivalled opportunity to enjoy them in peace and quiet. The *Agency of Living Organisms* will also be opened. The exhibition is curated by **Pauline Doutreluingne**, the Belgian curator, and observes the relations between the urban structures of society and nature. The month will end with the **Radio symposium LaPublika**. This live radio broadcast will be 15 hours of programming open to the public with concerts, performances, sound installations among the many activities organised.

In November, as part of the **City and Other Policies** project, the Tabakalera building itself will be studied and we will ask the question as to whether a building can achieve emancipation. There will also be new weekly workshops in Ubik: **Checkmate! Board Games Afternoon** and **Young Architect Club**, a new way of enjoying the creation library. At the end of November, as part of the programme curated by **Pablo La Parra**, the curator in residence, a two-day international meeting will be held to discuss militant cinema archives and delve further into the theme.

In December, as part of the **Space 0-6** programme, an interactive installation will be built using different materials in order to develop children's senses. We will also hold the 4th **Eginzaleak!** Digital Manufacturing and Technology Week and yet again this year, there will be a market where the general public can see the different projects.

There is clearly plenty to do and, above all, much to enjoy.

OCTOBER

1

Saturday

- **CONTEMPORARY CINEMA** (p. 24)
- **KAMALEOIAK GARA!** WHERE DOES YOUR BREAKFAST COME FROM? (pp. 50-51)
- **THE THREE CIRCULATIONS: ACTIVE SUBSTANCE. (P. 34)**
- **SALTO.** FAMILY CONVERSATIONS (p. 58)
- **SISTER OF ANOTHER MAMA** (p. 40)

2

Sunday

- **CINEMA AND ARCHITECTURE** (pp. 25-26)

3

Monday

- PRESENTATION OF THE EXHIBITION **ARCHITECTUS OMNIBUS?** (p. 20)

4

Tuesday

- **HIRIKIKAS.** OPEN FURNITURE DESIGN: EXPERIMENTING WITH MATERIALS AND SHAPES (p. 44)
- **NELL'S SCHOOL.** FREE LICENSES (p. 62)
- **YOUNG ARCHITECTS CLUB** (p. 63)

5

Wednesday

- MEETING WITH LOCAL ARCHITECTS. **ARCHITECTUS OMNIBUS?** (p. 20)
- **HIRIKIKAS.** INTRODUCTION TO DIGITAL MANUFACTURING: 3D PRINTING (p. 44)
- **WEDNESDAY AT UBIK** (p. 63)

6

Thursday

- **HIRIKILABS PLAZA 6.** (p. 46)

7

Friday

- **CHECKMATE!** BOARD GAMES EVENING (pp. 58-59)

8

Saturday

- **HISTORY, MEMORY AND WORK.** GET TO KNOW TABAKALERA (p. 18)
- **INTERNATIONAL FILM SEMINAR** (p. 30)
- **JOLABS.** DO IT IN FAMILY (p. 46)
- **KAMALEOIAK GARA!** PROGRAMA! 0-99 (p. 50)
- **I WANT TO BE A DJ!** (p. 60)
- **HORKONPON.** REPAIR WORKSHOP (p. 63)

9

Sunday

- **INTERNATIONAL FILM SEMINAR** (p. 30)

11

Tuesday

- **HIRIKIKAS.** OPEN FURNITURE DESIGN: EXPERIMENTING WITH MATERIALS AND SHAPES (p. 44)
- **I ALSO WANT!** (p. 62)
- **YOUNG ARCHITECTS CLUB** (p. 63)

12

Wednesday

- **WEDNESDAY AT UBIK** (p. 63)

13

Thursday

- **HIRIKILABS PLAZA 6** (p. 46)
- **KNOTS.** STIMULANTS: CIRCULATION AND EUPHORIA (p. 58)

14

Friday

- **THE LISTENING OBSERVATORY** (p. 37)
- **CHECKMATE!** BOARD GAMES EVENING (p. 58-59)

15

Saturday

- **EUROPE, FUTURE PAST** (pp. 28-29)
- **JOLABS.** DO IT IN FAMILY (p. 46)
- **PROGRAMME WITH TEACHERS.** MEETING 1: SCHOOL LABORATORY: CO-CREATING OUR SPACE (p. 55)
- **SELFI SELFIE.** SESSIONS TO IMPROVE YOUR SELFIES (p. 59)

18

Tuesday

- **HIRIKIKAS.** OPEN FURNITURE DESIGN: EXPERIMENTING WITH MATERIALS AND SHAPES (p. 44)
- **EXPERIMENTAL SCREEN** (p. 59)
- **YOUNG ARCHITECTS CLUB** (p. 63)

19

Wednesday

- MEETING WITH LOCAL ARCHITECTS. **ARCHITECTUS OMNIBUS?** (p. 20)
- **CINE Y ARQUITECTURA** (pp. 25-26)
- **HIRIKIKAS.** ALGORITHMIC NATURE (p. 44)
- **WEDNESDAY AT UBIK** (p. 63)

20

Thursday

- **HIRIKILABS PLAZA 6** (p. 46)
- **FANZINEMANIA!** (p. 60)
- **HUMAN LIBRARY** (p. 64)

21

Friday

- **AGENCY OF LIVING ORGANISMS.** EXHIBITION. OPENING. (p.15)
- PERFORMANCE **THE POSSIBILITY THAT DISAPPEARS IN FRONT OF THE LANDSCAPE.** (p. 15)
- **CHECKMATE!** BOARD GAMES EVENING (pp. 58-59)
- **VIDEO KILLED THE RADIO STAR** (pp. 58-59)

22

Saturday

- **BECAUSE WE MEET:** VAPOR / LIQUID / SOLID (p. 15)
- WALK-PERFORMANCE **GERARD ORTIN** (p. 16)
- **HISTORY, MEMORY AND WORK.** GET TO KNOW TABAKALERA (p. 18)
- **DOCUMENTARY FILM AND MEMORY:** MEETING WITH PATRICIO GUZMAN (p. 31)
- **JOLABS.** DO IT IN FAMILY (p. 46)
- **I WANT TO BE A DJ!** (p. 60)
- SELECTION OF VIDEO GAMES BY **LARA SÁNCHEZ COTERÓN** (p. 62)

23

Sunday

- GUIDED WALK. **A DANGEROUS WALK** (p. 16)
- WALK-PERFORMANCE **GERARD ORTIN** (p. 14)
- **KAMALEOIAK GARA!** EXHIBITION 5-99 (p. 50)

24

Monday

- **LIBRARY DAY** (p. 64)

25

Tuesday

- **HIRIKIKAS.** OPEN FURNITURE DESIGN: EXPERIMENTING WITH MATERIALS AND SHAPES (p. 44)
- **I ALSO WANT!** (p. 62)
- **YOUNG ARCHITECTS CLUB** (p. 63)
- **LIBRARY DAY** (p. 64)

26

Wednesday

- **HIRIKIKAS.** ALGORITHMIC NATURE (p. 44)
- **ATLAS.** DESKTOP PUBLISHING MEETINGS. "SOCIAL NETWORKS" OF THE 1960S (pp. 60-61)
- **WEDNESDAY AT UBIK** (p. 63)
- **LIBRARY DAY** (p. 64)

27

Thursday

- **HIRIKILABS PLAZA 6** (p. 46)
- **SMOKE POLITICS** (pp. 34-35)

28

Friday

- **HIRIA HACHEATU.** YOUNG PEOPLE, THE CITY AND MAKERS (p. 52)
- **BUILDING SPACE 0-6:** SOFT FURNITURE (p. 52)
- **CHECKMATE!** BOARD GAMES EVENING (pp. 58-59)
- **LAPUBLIKA** (pp. 40-41)

29

Saturday

- **CONTEMPORARY CINEMA** (p. 24)
- **HIRIKIKAS.** MAPATHON: MISSING MAPS (p. 44)
- **JOLABS.** DO IT IN FAMILY (p. 46)
- **SELFI SELFIE.** SESSIONS TO IMPROVE YOUR SELFIES (p. 59)
- **OUTLINE. CRITICAL THINKING** (p. 58)

30

Sunday

- **CONTEMPORARY CINEMA** (p. 24)

NOVEMBER

2

Wednesday

- **CITY AND OTHER POLICIES** – LA INSTITUCIÓN EMANCIPADA: TABAKALERA COMO ESCENARIO DE RESISTENCIA (p. 38)
- **YOUNG ARCHITECTS CLUB** (p. 63)
- **WEDNESDAY AT UBIK** (p. 63)

3

Thursday

- **CITY AND OTHER POLICIES** – LA INSTITUCIÓN EMANCIPADA: TABAKALERA COMO ESCENARIO DE RESISTENCIA (p. 38)
- **HIRIKILABS PLAZA 6** (p. 46)

4

Friday

- **FOR AN IMPOSSIBLE CINEMA:** DOCUMENTARY AND AVANT-GARDE IN CUBA (1959-1972) (pp. 26-27)
- **CITY AND OTHER POLICIES** – LA INSTITUCIÓN EMANCIPADA: TABAKALERA COMO ESCENARIO DE RESISTENCIA (p. 38)
- **BUILDING SPACE 0-6:** SOFT FURNITURE (p. 52)
- **CHECKMATE!** BOARD GAMES EVENING (pp. 58-59)

5

Saturday

- **KOMIKILABEA** (p. 29)
- **CITY AND OTHER POLICIES** – LA INSTITUCIÓN EMANCIPADA: TABAKALERA COMO ESCENARIO DE RESISTENCIA (p. 38)
- **JOLABS.** DO IT IN FAMILY (p. 46)
- **JOLABS.** EFFICIENT CREATION OF TEMPLATES (p. 46)
- **SALTO.** FAMILY CONVERSATIONS (p. 58)
- **I WANT TO BE A DJ!** (p. 60)
- **GETTING TO KNOW ARDUINO** (p. 63)
- **KOMIKILABEA.** COMIC BOOK WEEK (p. 64)

6

Sunday

- **FOR AN IMPOSSIBLE CINEMA:** DOCUMENTARY AND AVANT-GARDE IN CUBA (1959-1972). (pp. 26-27)
- **KAMALEOIAK GARA!** CINEMA 5-99 (p. 51)
- **KOMIKILABEA.** COMIC BOOK WEEK (p. 64)
- **STORYLINE.** MAKING A COMIC COLLECTIVE (pp. 64-65)

7

Monday

- **KOMIKILABEA.** COMIC BOOK WEEK (p. 64)
- **STORYLINE.** MAKING A COMIC COLLECTIVE (pp. 64-65)

8

Tuesday

- **YOUNG ARCHITECTS CLUB** (p. 63)
- **STORYLINE.** MAKING A COMIC COLLECTIVE (pp. 64-65)
- **ARQUITECTURA:** FILM LANGUAGES. EUROPE TAKEN (pp. 38-39)
- **HIRIKIKAS.** EXPERIMENTAL WORKSHOP ON GENERATIVE DESIGN AND NATURAL PATTERNS (p. 45)
- **NELL'S SCHOOL.** FREE SOFTWARE AND HARDWARE (p. 62)
- **I ALSO WANT!** (p. 62)
- **KOMIKILABEA.** COMIC BOOK WEEK (p. 64)

9

Wednesday

- **ARQUITECTURA:** FILM LANGUAGES. EUROPE TAKEN (pp. 38-39)
- **HIRIKIKAS.** EXPERIMENTAL WORKSHOP ON GENERATIVE DESIGN AND NATURAL PATTERNS (p. 45)
- **WEDNESDAY AT UBIK** (p. 63)
- **KOMIKILABEA.** COMIC BOOK WEEK (p. 64)
- **STORYLINE.** MAKING A COMIC COLLECTIVE (pp. 64-65)
- **¿MÁS CLARO?** IN COMICS! A SELECTION OF SOCIAL COMICS BY DAVID ZAPIRAIN (p. 65)

10

Thursday

- **ARQUITECTURA:** FILM LANGUAGES. EUROPE TAKEN (pp. 38-39)
- **HIRIKILABS PLAZA 6** (p. 46)
- **KOMIKILABEA.** COMIC BOOK WEEK (p. 64)
- **STORYLINE.** MAKING A COMIC COLLECTIVE (pp. 64-65)
- **SUPERWOMEN.** A FRESH LOOK AT THE USUAL POINT OF VIEW (p. 65)

11

Friday

- **FOR AN IMPOSSIBLE CINEMA:** DOCUMENTARY AND AVANT-GARDE IN CUBA (1959-1972) (pp. 26-27)
- **ARQUITECTURA:** FILM LANGUAGES. EUROPE TAKEN (pp. 38-39)
- **CHECKMATE!** BOARD GAMES EVENING (pp. 58-59)
- **KOMIKILABEA.** COMIC BOOK WEEK (p. 64)
- **STORYLINE.** MAKING A COMIC COLLECTIVE (pp. 64-65)

12

Saturday

- **HISTORY, MEMORY AND WORK.** GET TO KNOW TABAKALERA (p. 18)
- **JOLABS.** DO IT IN FAMILY (p. 46)
- **GEHITU:** SEBASTIANE AWARD (p. 31)
- **KAMALEOIAK GARA!** PROGRAMME! 0-99 (p. 50)
- **SELFI SELFIE.** SESSIONS TO IMPROVE YOUR SELFIES (p. 59)
- **GETTING TO KNOW ARDUINO** (p. 63)
- **HORKONPON.** REPAIR WORKSHOP (p. 63)
- **KOMIKILABEA.** COMIC BOOK WEEK (p. 64)
- **STORYLINE.** MAKING A COMIC COLLECTIVE (pp. 64-65)

13

Sunday

- **CONTEMPORARY CINEMA** (p. 24)

14

Monday

- **CURATORIAL PROGRAMME:** CURATOR OF RESEARCH (p. 68)

15

Tuesday

- **HIRIKIKAS.** WORKSHOP ON PARAMETRIC DESIGN AND MANUFACTURING IN PAPER WITH VVVV (p. 45)
- **KNOTS.** STIMULANTS: CIRCULATION AND EUPHORIA (p. 58)
- **EXPERIMENTAL SCREEN** (p. 59)
- **YOUNG ARCHITECTS CLUB** (p. 63)
- **CURATORIAL PROGRAMME:** CURATOR OF RESEARCH (p. 68)

16

Wednesday

- **HIRIKIKAS.** WORKSHOP ON PARAMETRIC DESIGN AND MANUFACTURING IN PAPER WITH VVVV (p. 43)
- **WEDNESDAY AT UBIK** (p. 61)
- **CURATORIAL PROGRAMME:** CURATOR OF RESEARCH (p. 68)

17

Thursday

- **OUT OF SYNC.** LOUDER, FASTER, STRONGER (pp. 36-37)
- **HIRIKILABS PLAZA 6** (p. 46)
- **EMPOWERING TECHNOLOGY.** FREE SOFTWARE AND TECHNOLOGY MEETINGS (p. 46)
- **OUTLINE.** CRITICAL THINKING (p. 58)
- **CURATORIAL PROGRAMME:** CURATOR OF RESEARCH (p. 68)

18

Friday

- **FOR AN IMPOSSIBLE CINEMA:** DOCUMENTARY AND AVANT-GARDE IN CUBA (1959-1972) (pp. 26-27)
- **OUT OF SYNC.** LOUDER, FASTER, STRONGER (pp. 36-37)
- **CHECKMATE!** BOARD GAMES EVENING (pp. 58-59)
- **VIDEO KILLED THE RADIO STAR** (p. 63)
- **CURATORIAL PROGRAMME:** CURATOR OF RESEARCH (p. 68)

19

Saturday

- **CINEMA AND ARCHITECTURE** (pp. 25-26)
- **OUT OF SYNC.** LOUDER, FASTER, STRONGER (pp. 36-37)
- **JOLABS.** DO IT IN FAMILY (p. 46)
- **KAMALEOIAK GARA!** WHERE DOES YOUR BREAKFAST COME FROM? (pp. 50-51)
- **I WANT TO BE A DJ!** (p. 61)
- **GETTING TO KNOW ARDUINO** (p. 63)

NOVEMBER

20

Sunday

- **FOR AN IMPOSSIBLE CINEMA:** DOCUMENTARY AND AVANT-GARDE IN CUBA (1959-1972) (pp. 26-27)

22

Tuesday

- **HIRIKIKAS.** OPEN FURNITURE DESIGN: EXPERIMENTING WITH MATERIALS AND SHAPES (p. 44)
- **EXHIBITION OF THE ZINES OF THE ZONE COLLECTION** (p. 61)
- **I ALSO WANT!** (p. 62)
- **YOUNG ARCHITECTS CLUB** (p. 63)

23

Wednesday

- **HIRIKIKAS.** EXPERIMENTAL WORKSHOP ON GENERATIVE DESIGN AND NATURAL PATTERNSNATURALES (p. 45)
- **ATLAS.** DESKTOP PUBLISHING MEETINGS. Meeting with zines in the area, a mobile library of fanzine desktop publishing. (pp. 60-61)
- **EXHIBITION OF THE ZINES OF THE ZONE COLLECTION** (p. 61)
- **WEDNESDAY AT UBIK** (p. 63)

24

Thursday

- **SMOKE POLITICS** (pp. 34-35)
- **HIRIKILABS PLAZA 6** (p. 46)
- **EXHIBITION OF THE ZINES OF THE ZONE COLLECTION** (p. 61)

25

Friday

- **EUROPE, FUTURE PAST.** INTERNATIONAL SYMPOSIUM: THE CAPTURE OF SPEECH. DIALOGUES WITH THE MILITANT CINEMA ARCHIVE (pp. 28-29)
- **HIRIA HACHEATU.** YOUNG PEOPLE, THE CITY AND MAKERS (p. 52)
- **CHECKMATE!** BOARD GAMES EVENING (pp. 58-59)

26

Saturday

- **HISTORY, MEMORY AND WORK.** GET TO KNOW TABAKALERA (p. 18)
- **EUROPE, FUTURE PAST.** INTERNATIONAL SYMPOSIUM: THE CAPTURE OF SPEECH. DIALOGUES WITH THE MILITANT CINEMA ARCHIVE (pp. 28-29)
- **JOLABS.** DO IT IN FAMILY (p. 46)
- **OUTLINE.** CRITICAL THINKING (p. 58)
- **SELF! SELFIE.** SESSIONS TO IMPROVE YOUR SELFIES (p. 61)
- **GETTING TO KNOW ARDUINO** (p. 63)

27

Sunday

- **FOR AN IMPOSSIBLE CINEMA:** DOCUMENTARY AND AVANT-GARDE IN CUBA (1959-1972) (pp. 26-27)
- **KAMALEOIAK GARA!** EXPHIBITION 5-99 (p. 50)

28

Monday

- **ARQUITECTURA:** LENGUAJES FÍLMICOS. EUROPA TOMADA (pp. 38-39)

29

Tuesday

- **ARCHITECTURE:** FILM LANGUAGES. EUROPE TAKEN (pp. 38-39)
- **HIRIKIKAS.** OPEN FURNITURE DESIGN: EXPERIMENTING WITH MATERIALS AND SHAPES (p. 44)
- **YOUNG ARCHITECTS CLUB** (p. 63)

30

Wednesday

- **BUILDING SPACE 0-6:** ISENSORY INSTALLATION (p. 50)
- **WEDNESDAY AT UBIK** (p. 63)



DECEMBER

1

Thursday

- **BUILDING SPACE 0-6:** SENSORY INSTALLATION (p. 52)

2

Friday

- **CONTEMPORARY CINEMA** (p. 24)
- **CHECKMATE!** BOARD GAMES EVENING (pp. 58-59)

3

Monday

- **CONTEMPORARY CINEMA** (p. 25)
- **JOLABS.** DO IT IN FAMILY (p. 46)
- **SALTO.** FAMILY CONVERSATIONS (p. 58)
- **ENDPLAY:** AN OBSERVATORY (p. 68)
- **SOUND CINEMA - CITYSCAPES** (p. 41)

4

Sunday

- **FOR AN IMPOSSIBLE CINEMA:** DOCUMENTARY AND AVANT-GARDE IN CUBA (1959-1972) (pp. 26-27)
- **SOUND CINEMA - CITYSCAPES** (p. 41)
- GUIDED WALK. **A DANGEROUS WALK** (p. 16)

6

Tuesday

- **YOUNG ARCHITECTS CLUB** (p. 63)

7

Wednesday

- **MEETINGS ON THE ARTIST'S BOOK** (pp. 61-62)
- **WEDNESDAY AT UBIK** (p. 63)

8

Thursday

- **HIRIKILABS PLAZA 6** (p. 46)
- **MEETINGS ON THE ARTIST'S BOOK** (pp. 61-62)

9

Friday

- **FOR AN IMPOSSIBLE CINEMA:** DOCUMENTARY AND AVANT-GARDE IN CUBA (1959-1972) (pp. 26-27)
- **CHECKMATE!** BOARD GAMES EVENING (pp. 58-59)
- **MEETINGS ON THE ARTIST'S BOOK** (pp. 61-62)

10

Saturday

- **HISTORY, MEMORY AND WORK.** GET TO KNOW TABAKALERA (p. 18)
- **CONTEMPORARY CINEMA** (p. 25)
- **EUROPE, FUTURE PAST.** ZINETRAKTATU! (pp. 28-29)
- **JOLABS.** DO IT IN FAMILY (p. 46)
- **HORKONPON.** REPAIR WORKSHOP (p. 63)

11

Sunday

- **EUROPE, FUTURE PAST.** ZINETRAKTATU! (pp. 28-29)
- **EUROPE, FUTURE PAST.** CARTE BLANCHE TO STOFFEL DEBUYSERE (pp. 28-29)
- **KAMALEOIAK GARA!** CINEMA 5-99 (p. 53)

12

Monday

- **FEMINIST STRATEGIES IN EDUCATION.** FEMINISTALDIA (p. 53)

13

Tuesday

- **EGINZALEAK !** 4TH CITIZEN TECHNOLOGY AND MANUFACTURING WEEK (p. 49)
- **FEMINIST STRATEGIES IN EDUCATION.** FEMINISTALDIA (p. 53)
- **I ALSO WANT!** (p. 65)
- **NELL'S SCHOOL.** BASICS OF PROGRAMMING (pp. 64-65)
- **YOUNG ARCHITECTS CLUB** (p. 65)

14

Wednesday

- **EGINZALEAK !** 4TH CITIZEN TECHNOLOGY AND MANUFACTURING WEEK (p. 49)
- **WEDNESDAY AT UBIK** (p. 65)
- **FEMINISTALDIA** (p. 41)

15

Thursday

- **HIRIKILABS PLAZA 6** (p. 48)
- **EGINZALEAK !** 4TH CITIZEN TECHNOLOGY AND MANUFACTURING WEEK (p. 49)
- **KNOTS.** STIMULANTS: CIRCULATION AND EUPHORIA (p. 60)
- **FEMINISTALDIA** (p. 41)

16

Friday

- **CARTE BLANCHE:** FEMINISTALDIA 2016 - #PLAZA (p. 29)
- **EGINZALEAK !** 4TH CITIZEN TECHNOLOGY AND MANUFACTURING WEEK (p. 49)
- **CHECKMATE!** BOARD GAMES EVENING (pp. 58-59)
- **VIDEO KILLED THE RADIO STAR** (p. 61)
- **EXPERIMENTAL SCREEN** (p. 59)
- **FEMINISTALDIA** (p. 41)

17

Saturday

- **JOLABS.** DO IT IN FAMILY (p. 46)
- **EGINZALEAK !** 4TH CITIZEN TECHNOLOGY AND MANUFACTURING WEEK (p. 49)
- **FEMINISTALDIA** (p. 41)
- **OUTLINE.** CRITICAL THINKING (pp. 58-59)

18

Sunday

- **FOR AN IMPOSSIBLE CINEMA:** DOCUMENTARY AND AVANT-GARDE IN CUBA (1959-1972). (pp. 26-27)
- **KAMALEOIAK GARA!** EXHIBITION 5-99 (p. 50)

20

Tuesday

- **YOUNG ARCHITECTS CLUB** (p. 63)
- **EXPERIMENTAL SCREEN** (p. 59)

21

Wednesday

- **WEDNESDAY AT UBIK** (p. 63)

22

Thursday

- **HIRIKILABS PLAZA 6** (p. 46)

23

Friday

- **FOR AN IMPOSSIBLE CINEMA:** DOCUMENTARY AND AVANT-GARDE IN CUBA (1959-1972) (pp. 26-27)
- **CHECKMATE!** BOARD GAMES EVENING (pp. 58-59)

24

Saturday

- **HISTORY, MEMORY AND WORK.** GET TO KNOW TABAKALERA (p. 18)
- **JOLABS.** DO IT IN FAMILY (p. 46)

25

Sunday

- **CONTEMPORARY CINEMA** (p. 25)

27

Tuesday

- **HIRIA HACHEATU.** YOUNG PEOPLE, THE CITY AND MAKERS (p. 52)
- **I ALSO WANT!** (p. 62)
- **YOUNG ARCHITECTS CLUB** (p. 63)
- **WINTER WORKSHOPS** (p. 65)

28

Wednesday

- **HIRIA HACHEATU.** YOUNG PEOPLE, THE CITY AND MAKERS (p. 52)
- **ATLAS.** DESKTOP PUBLISHING MEETINGS. Fanzine II. Closure of the European Capital of Culture. (pp. 60-61)
- **WEDNESDAY AT UBIK** (p. 63)
- **WINTER WORKSHOPS** (p. 65)

29

Thursday

- **HIRIKILABS PLAZA 6** (p. 46)
- **HIRIA HACHEATU.** YOUNG PEOPLE, THE CITY AND MAKERS (p. 52)
- **WINTER WORKSHOPS** (p. 65)

30

Friday

- **FOR AN IMPOSSIBLE CINEMA:** DOCUMENTARY AND AVANT-GARDE IN CUBA (1959-1972) (pp. 26-27)
- **HIRIA HACHEATU.** YOUNG PEOPLE, THE CITY AND MAKERS (p. 52)
- **CHECKMATE!** BOARD GAMES EVENING (pp. 58-59)
- **WINTER WORKSHOPS** (p. 65)

31

Saturday

- **JOLABS.** DO IT IN FAMILY (p. 46)

EXHIBITION

Index

YTO BARRADA

AGENCY OF LIVING ORGANISMS

· RELATED ACTIVITIES

MAÑANA GOODBYE. WOMEN WORKING TOGETHER

· RELATED ACTIVITIES

12 PER MINUTE

ARCHITECTUS OMNIBUS?

· RELATED ACTIVITIES

AGENCY OF LIVING ORGANISMS,
Pauline Doutreluingne.

Exhibition's hall opening hours:

From Tuesday to Thursday: 12:00 - 20:00

Friday: 12:00 - 21:00

Saturday: 10:00 - 21:00

Sunday and holidays: 10:00 - 20:00

08/07/2016 > 09/10/2016

Exhibition

YTO BARRADA

📍 Exhibition hall

Tabakalera presents the first solo exhibition in the Spanish state by French-Moroccan artist Yto Barrada. The show includes videos, photographs and sculptures of her new work, as well as some older pieces. Among the pieces is a selection of videos exploring the work of a smuggler, a magician and traders in fossils from Morocco. A serie of photographs documents a French ethnographer's collection of toys. Subtly and captivatingly, the work of Yto Barrada draws in questions of history, geography, geology, the invention of tradition and the meaning of the modern.

Yto Barrada (Paris, 1971) studied History and Political Science at the Sorbonne and photograph in New York. Her work, which includes photographs, sculptures, publications and installations, began by exploring the situation of the Tangier of her childhood. Her work has been exhibited at the Tate Modern (London), MoMA (New York), the Renaissance Society (Chicago), the Witte de With (Rotterdam), the Haus der Kunst (Munich), the Centre Pompidou (Paris), the Whitechapel Gallery (London) and at the Venice Biennale (2007 and 2011). Barrada is also a founder and director of the Cinémathèque de Tanger.

In collaboration with Institut Français.



Yto Barrada

21/10/2016 > 05/02/2017

Exhibition

AGENCY OF LIVING ORGANISMS

Curator: *Pauline Doutreluingne*.

Artists: *Lara Almarcegui, Anne Duk Hee Jordan, Tue Greenfort, Iratxe Jaio y Klaas van Gorkum, Esther Kokmeijer, Nader Koochaki, Maider Lopez, Gerard Ortin, Tere Recarens, Koenraad Van den Driessche, Johansons Voldemars, El Conde de Torreñiel*

📍 Exhibition hall

Agency of Living Organisms exhibition is devoted to the project developed by Pauline Doutreluingne during her residency in Tabakalera in autumn 2015 as a result of the first open call for curators. *Agency of*

Living Organisms is an exhibition that observes the interaction and communication between phenomena within different ecosystems throughout the lithosphere, atmosphere, biosphere, and hydrosphere.

In response to the theme in question, the project proposes an exhibition with interconnected commissioned and existing works as a social living sculpture, an expanding format that opens the walls of the museum into the urban, natural and 'online' environment.

With the collaboration of: Goethe Institut, Mondriaan Foundation and Latvian Culture Foundation RIGA.

RELATED ACTIVITIES

21 OCTOBER (Friday)

OPENING

19:00

📍 Exhibition hall

21 OCTOBER (Friday)

Performance

THE POSSIBILITY THAT DISAPPEARS IN FRONT OF THE LANDSCAPE

El Conde de Torreñiel

20:30

📍 Square

This work is about reading and observation. Designed as an open book, the piece describes and narrates the indiscernible atmospheres, thoughts and memories of the world.

22 OCTOBER (Saturday)

Conference

BECAUSE WE MEET: VAPOR / LIQUID / SOLID

Esther Kokmeijer

17:00

📍 Workshop

The artist will give a talk based on her research project on the need to control nature from the perspective of the three states of water and the way in which the human being interacts with it.



Lycisca, Gerard Ortin

22, 23 OCTOBER (Saturday, Sunday)

Performance

GERARD ORTIN

20:00

Registration required.

During this walk, Ortin will explore with the participants the nervous system of the urban space, thus turning the city itself into a living organism.

23 OCTOBER, 4 DECEMBER,

21 ENERO (Sunday, Saturday)

Guided walk

A DANGEROUS WALK

Koenraad Van den Driesche

11:00 / Duration: 90'

Registration required.

📍 From Tabakalera

Under the guidance of Van den Driesche, the geologist, you will discover the geological evolution of Donostia-San Sebastián.

6 NOVEMBER, 11 DECEMBER (Sunday)

Guided walk

FOSSILS IN THE CITY

Koenraad Van den Driesche

11:00 / Duration: 90'

Registration required.

📍 From Tabakalera

Cities are improvised paleontological museums, brimming with details that help to analyse the past through fossils and tracks. During this walk, Van den Driesche, the geologist, will show you how to read those signs.

13 NOVEMBER (Sunday)

Guided walk

WALK THROUGH DEEP TIME

Koenraad Van den Driesche

11:00 / Duration: 90'

Registration required.

📍 From Tabakalera

The geologist proposes a walk when the time line of the planet will be drawn.

11 FEBRUARY 2017 (Saturday)

Performance

CORRER O MORIR

(Run or die)

Nader Koochaki

18:30

📍 Exhibition hall

Nader Koochaki aims to read aloud the book *Correr o Morir* by Kilian Jornet as quickly as possible, from beginning to end. This is a single reading, as an action, without rehearsals or purpose.

2, 16 NOVEMBER, 7, 21 DECEMBER

(Wednesday)

Visit

VISIT IN DIALOGUE

18:00 ES / 19:00 EU

*Sign Language Interpretation Service (SLIS) available by booking in advance.

Registration required.

📍 Sala de exposiciones

Through the *Visits in Dialogue*, we propose to delve into the world of exhibitions. They are paths to making direct contact with contemporary art, in which anyone interested can participate.

30 NOVEMBER, 28 DECEMBER

(Wednesday)

Visit

EXPERIMENTAL VISITS

18:30

Registration required.

📍 Exhibition hall

These visits are intended to invite educators, scientists, biologists, historians, anthropologists, students... to open up new

interpretations and add layers of meaning to the exhibitions. The idea is to bring about unexpected encounters in the halls to allow trips and tours that would not happen otherwise.

30 November

Miren Cajaraville, Professor of Cell Biology.

28 December

Amalia Martínez de Murguía, Coordinator of the Biology and Research Department of the Donostia-San Sebastian Aquarium.

08 NOVEMBER, 13 DECEMBER,

10 JANUARY (Tuesday)

Learning group

TESTU-INGURUAN. APPROACH TO CONTEMPORARY ART

18:30 EU / ES

Registration required.

Aimed at: anyone interested. It is not necessary to have any prior knowledge of contemporary art.

Testu-inguruan is a programme that accompanies Tabakalera exhibitions aimed at anyone interested in contemporary art. They are monthly sessions which delve into the contents of exhibitions through materials such as texts, pieces or films. The idea is to provide tools for self-training on subjects related to contemporary art.

09/2015 > 12/2016

Exhibition

MAÑANA GOODBYE. WOMEN WORKING TOGETHER

Chapters 10, 11, 12

Coordination: Marión Cruza,
Pablo Marte

📍 Storage

From February 2015 we are working with two artists, a group of former Tabakalera workers and a group of actresses on the project *Mañana Goodbye*. This is a 12-part series exploring the change in the production model by which the old tobacco factory became the current International Contemporary Culture Centre. Lurking in the wings are two big questions: what do we need from the past when it comes to work and how and from where can one talk about memory? In its second phase, the project was accompanied by a programme of activities entitled *After leaving the factory*.

Mañana Goodbye can be visited in the Storage, where the series is exhibited by way of an audiovisual installation, adding a new chapter every month until the end of 2016. Thereafter, the work will continue to be installed in the same place and will be used by various mediation programmes.

RELATED ACTIVITIES

8, 22 OCTOBER, 12, 26 NOVEMBER

10, 24 DECEMBER (Saturdays)

Visit

HISTORY, MEMORY AND WORK

Get to know Tabakalera

11:00 EU / 12:00 ES

*Sign Language Interpretation Service (SLIS) available by booking in advance.

📍 Information point.

Tabakalera has its headquarters in the old tobacco factory in the city, the building being founded in 1913. These tours revolve around the following axes, among others: the *Mañana Goodbye* project, the history and uniqueness of the architectural space, the experiences and memories of the lives of its workers and the new areas and uses that have come from the remodelling.

Work process

ARE WE STILL WORKING TOGETHER?

Based on the experiences shared during the *Mañana Goodbye* process, we will set up a space for former and current Tabakalera workers. The proposal is to include the work and relationships already generated and, at the same time, find new allies who will join us in wanting to continue reflecting on the past and the present uses of the building. We will start a process in which we will invite former workers of the tobacco factory to share and exchange their life experiences and memories.



12 PER MINUTE, Natalia Bażowska

08/09/2016 > 04/12/2016

Installation

MEETING OF THE PROJECT ROOMS 12 PER MINUTE

Artist: Natalia Bażowska

Curator: Magda Kardasz

From Monday to Sunday: 10:00-20:00

📍 Hall floor 2

Natalia Bażowska, the Polish artist, unveils an installation based on the sea and its relation with humans, inspired by her time spent at different points of the coast of Gipuzkoa.

The project is composed by an installation entitled *Concha*, which allows the public the illusion of immersing in the water and isolate from the external world. The

installation is accompanied with the sound of the artist breathing at 12 seconds per minute. The video *Fondness* is a visual and aural description of the longing for water and the calmness it recalls. The project is completed with oil paintings, as a record of the artist's solitary walk on the shore.

12 Per Minute is part of *Meeting of the Project Rooms*, a project curated by Magda Kardasz, that presents the work of three young Polish artists –Jaśmina Wójcik, Michał Frydrych and Natalia Bażowska– who represent different creative approaches referring to the local context or the history of the space.

This project has been produced for Tabakalera with the collaboration of Polish Institute in Madrid.

03/10/2016 > 30/10/2016

Exhibition

ARCHITECTUS OMNIBUS?

📍 Square

Architectus Omnibus? is an exhibition that shows the result of the open call to architecture studios and students to propose new responses to the needs of society. The project is based on a decalogue of ten concepts designed by the architect Andrés Jaque and the ten projects selected show various proposals from Spanish and German architects, pursuing the sustainable awareness of architecture through new attitudes and ways of understanding the profession.

The project falls within the 6th German-Spanish Cultural Encounter organised and produced by the Goethe-Institut and the Instituto Cervantes in 2015.

RELATED ACTIVITIES

Presentation

3 OCTOBER (Monday)

PRESENTATION OF THE PROJECT

18:00

📍 Square

Meeting

5, 19 OCTOBER (Wednesday)

MEETING WITH LOCAL ARCHITECTS

18:00

📍 Square

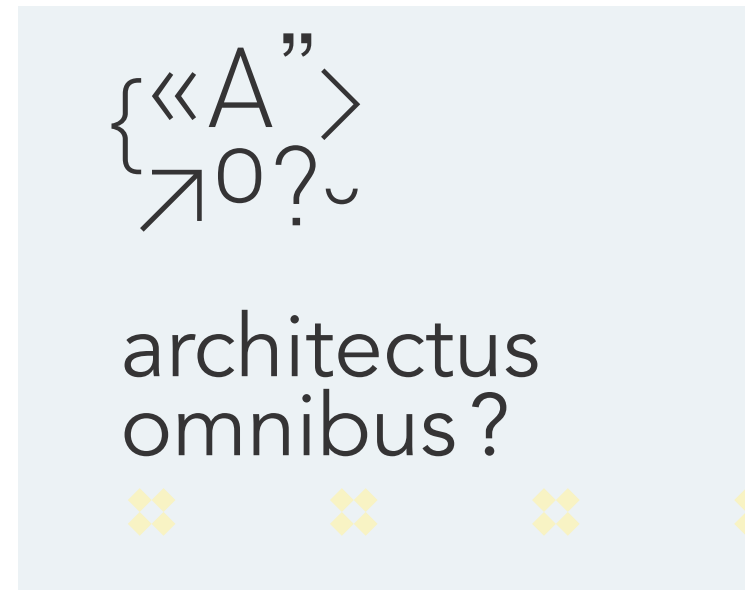

Architectus Omnibus?

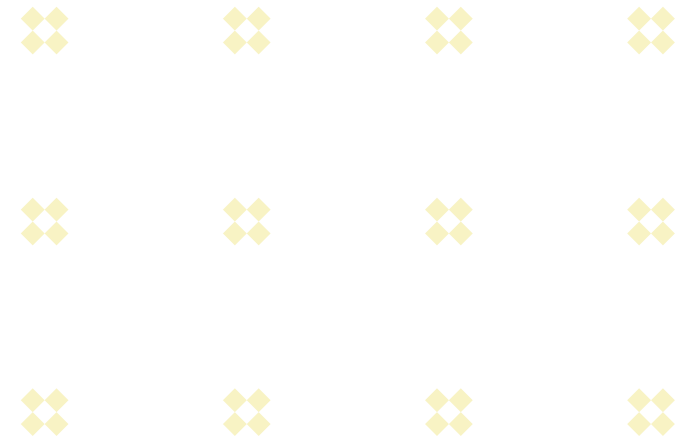

CINE- MA

Index

SEASONS

- ZABALTEGI-TABAKALERA
- CONTEMPORARY CINEMA
- CINEMA AND ARCHITECTURE
- FOR AN IMPOSSIBLE CINEMA: DOCUMENTARY AND AVANT-GARDE IN CUBA (1959-1972).
- EUROPE, FUTURE PAST
- KOMIKILABEA

CARTES BLANCHES

- FEMINISTALDIA 2016 - #PLAZA

KAMALEOIAK GARA! CINEMA

INTERNATIONAL FILM SEMINAR

PROGRAMME AT TABAKALERA

- GEHITU: SEBASTIANE AWARD
- CRISTINA ENEA: PATRICIO GUZMÁN

Homo Sapiens
Nikolaus Geyrhalter, Austria 2016.



OCTOBER

**SEASON:
ZABALTEGI-TABAKALERA**

The new Zabaltegi-Tabakalera competition section will occupy the hall in October: we have five feature films and five short films for audiences that were unable to see them during San Sebastian International Film Festival.

30 SEPTEMBER (Friday)

20:00

El extraño (The Stranger), Pablo Álvarez, Chile / Spain, 2016.
Zoologiya, Ivan T. Tverdovskiy, Russia / France / Germany, 2016, 90', OV with Spanish subtitles.

14 OCTOBER (Friday)

20:00

The Hedonists, Jia Zhangke, China, 2016, 26', OV with Basque subtitles.
A cidade onde envelheço (Where I Grow Old), Marília Rocha, Brazil/Portugal, 2016, 99', OV with Basque subtitles.

16 OCTOBER (Sunday)

19:00

Gure hormek, Las chicas de Pasaik, María Elorza and Mainer Fernández, Spain, 2016, 15', OV with Spanish subtitles.
Louise en hiver (Louise In Winter), Jean-Françoise Laguionie, France, 2016, 75', OV with Basque subtitles.

23 OCTOBER (sunday)

19:00

489 Years, Hayoun Kwon, France, 2016, 12', OV with Basque subtitles.
El viento sabe que vuelvo a casa, (The Winds Know That I'm Coming Back Home), José Luis Torres Leiva, Chile, 2016, 102'.

28 OCTOBER (Friday)

20:00

Caminan, Mikel Rueda, Spain, 2016, 14'.
The Illinois Parables, Deborah Stratman, USA, 2016, 60', OV with Spanish subtitles.

**SEASON:
CONTEMPORARY CINEMA**

Author cinema, films from the international festival circuit and independent distributors.

1 OCTOBER (Saturday)

20:00

Saint Laurent, Bertrand Bonello, France, 2014, 150', OV with Spanish subtitles.

29 OCTOBER (Saturday)

20:00

Oleg y las raras artes (Oleg and the Rare Arts), Andrés Duque, Spain, 2016, 70'.
With the director.

30 OCTOBER (Sunday)

19:00

Dead Slow Ahead, Mauro Herce, Spain/France, 2015 74', OV with Spanish subtitles.
With the director.

13 NOVEMBER (Sunday)

News from Ideological Antiquity - Marx/Eisenstein/The Capital, Alexander Kluge, Germany, 2008, 490' (8 hours and 16 minutes). OV with Spanish subtitles.

10:00 - First part: *Marx y Eisenstein en la misma casa* (188').

15:00 - Second part: *Todas las cosas son personas embrujadas* (120').

18:00 - Third part: *Paradojas de la sociedad del intercambio* (182').

2 DECEMBER (Friday)

20:00

Ingen Ko Pa Isen / No Cow On The Ice, Eloy Dominguez Seren, Sweden/Spain, 2015, 63', OV with Spanish subtitles.
With the director.

3 DECEMBER (Saturday)

20:00

Faire la parole, Eugene Green, France, 2015, 116', OV with Spanish subtitles.

10 DECEMBER (Saturday)

20:00

Apology / Anthology

Session organised in the cinema in conjunction with the UPV/EHU, presenting a review of the history of video art in the Basque Country, with the attendance of the participating artists for an anthology edited by Cameo, under the direction of Hamaca, Tabakalera and the UPV / EHU. The *Apology / Anthology* project came about from the need to make nearly fifty years of audiovisual artistic production in Spain accessible, with the aim of making the multiple genealogies, connections and dialogues between different works and artists legible.

25 DECEMBER (Sunday)

19:00

El año más corto (The Shortest Year)
Review of the best Spanish short films presented at the international film festivals.

**SEASON:
CINEMA AND ARCHITECTURE**

Autumn is the season of architecture: on the one hand, there is the celebration of World Architecture Day on the first Monday in the month of October. On the other, with our various programmes dedicated to new urbanism, construction and a reflection on art and the technique of planning, designing, building and modifying the human habitat. The audiovisual area will offer three titles that address architecture purely from the cinematic. This year, we are focusing on the relationship between architecture and historical memory.

The idea of this cycle is to add and remove layers of discourse to and from a building: from a voice-over generating "politics" from the apparent neutrality of a building, to merely viewing it without adding speech. All to find, in the end, that the architecture itself includes the human dimension in its essence and, therefore, the possibility of complete destruction.

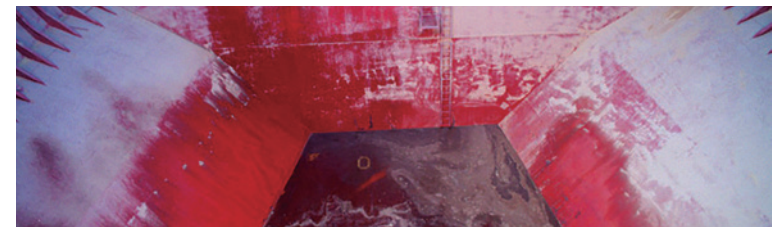

Dead Slow Ahead, Mauro Herce, 2015

2 OCTOBER (Sunday)

19:00

La ciudad del trabajo (City Of Work), Guillermo G. Peydró, Spain, 2016, 61'.
With the director.

19 OCTOBER (Wednesday)

19:00

The Airstrip, Heinz Emigholz, Germany, 2013, 108', OV with Spanish subtitles.

19 NOVEMBER (Saturday)

20:00

Homo Sapiens, Nikolaus Geyrhalter, Austria 2016, 94', OV with Spanish subtitles.

**SEASON:
FOR AN IMPOSSIBLE CINEMA,
DOCUMENTARY AND AVANT-
GARDE IN CUBA (1959-1972).**

Curated by film historian Michael Chanan and organised by the Museo Nacional Centro de Arte Reina Sofía, in collaboration with Cinemateca de Cuba, Tabakalera welcomes this season, which is dedicated to the Cuban documentary movement about the Revolution. Twelve sessions to learn about an episode in avant-garde Latin America which is usually ignored and a unique opportunity to access the original material that made up the visual and ideological imaginary of the revolution.



4 NOVEMBER (Friday)

20:00

Session 1. Beginnings (87').

El Mégano, Julio García Espinosa and Tomás Gutiérrez Alea, 1955, 25'.
La vivienda, Julio García Espinosa, 1959, 21'.

Sexto aniversario, Julio García

Espinosa, 1959, 18'.

Asamblea General, Tomás

Gutiérrez Alea, 1960, 14'.

Noticiero 49, Santiago Álvarez, 1961, 9'.

6 NOVEMBER (Sunday)

19:00

Session 2. Battles (102').

Cuba, pueblo armado, Joris Ivens, 1961, 35'.

Historia de una batalla, Manuel Octavio Gómez, 1962, 39'.

Ciclón, Santiago Álvarez, 1963, 22'.

Now, Santiago Álvarez, 1965, 6'.

11 NOVEMBER (Friday)

20:00

Session 3. Third World (112').

Una isla para Miguel, Sara Gómez, 1968, 22'.

Tercer mundo, Julio García Espinosa, 1970, 90'.

18 NOVEMBER (Friday)

20:00

Session 4. Perspectives I (120').

Gente en la playa, Néstor Almendros, 1961, 10'.

Hombres del cañaveral, Pastor Vega, 1965, 10'.

Guantánamo, José Massip, 1967, 62'.

Madina-Boe, José Massip, 1968, 38'.

20 NOVEMBER (Sunday)

19:00

Session 5. Santiago Álvarez. (116').

Cerro Pelado, Santiago Álvarez, 1966, 59'.

Hanói, martes 13, Santiago Álvarez, 1967, 38'.

Hasta la victoria siempre, Santiago Álvarez, 1967, 20'.

27 NOVEMBER (Sunday)

19:00

Session 6. Cultural (113').

Por primera vez, Octavio Cortázar, 1967, 10'.

Nuestra Olimpiada en La Habana, José Massip, 1968, 19'.

Acerca de un personaje que llaman San Lázaro y otros

llaman Babalú, Octavio Cortázar, 1968, 20'.

En la otra isla, Sara Gómez, 1968, 41'.

Hablando del punto cubano, Octavio Cortázar, 1972, 23'.

4 DECEMBER (Sunday)

19:00

Session 7. Perspectives II (119').

Hombres de Mal Tiempo, Alejandro Saderman, 1968, 32'.

LBJ, Santiago Álvarez, 1968, 18'.

Despegue a las 18:00, Santiago

Álvarez, 1969, 41'.

Café Árbiga, Nicolás Guillén Landrián, 1968, 18'.

Isla del Tesoro, Sara Gómez, 1969, 10'.

9 DECEMBER (Friday)

20:00

Session 8. Long struggles (109').

79 primavera, Santiago Álvarez, 1969, 25'.

La primera carga al machete,

Manuel Octavio Gómez, 1969, 84'.

17 DECEMBER (Saturday)

20:00

Session 9: Outsiders (118').

Yanki No! Robert Drew Associates, 1960, 60'. OV with Basque subtitles.

La Bataille des Dix Millions, Chris Marker, 1970, 58'. OV with Basque subtitles.

18 DECEMBER (Sunday)

19:00

Session 10. Women (108').

Salut les Cubains, Agnès Varda, 1962, 28'.

Ella, Theodor Christensen, 1964, 35'.

Iré a Santiago, Sara Gómez, 1964, 15'.

Y tenemos sabor, Sara Gómez, 1967, 30'.

23 DECEMBER (Friday)

20:00

Session 11. Perspectives III.

¡Viva la República! Pastor Vega, 1972, 100'.

30 DECEMBER (Friday)

20:00

Sesión 12. Lente ancha.

Girón, Manuel Herrera, 1972, 120'.



For an impossible cinema, documentary and avant-garde in Cuba (1959-1972)

**SEASON:
EUROPE, FUTURE PAST**

Programme curated by Pablo La Parra under the framework of the residency that Tabakalera and DSS2016EU launched jointly. The *Europe, Future Past* project explores transfers between the militant film archive and contemporary visual and artistic practices.

15 OCTOBER (Saturday)

20:00

Die Worte des Vorsitzenden

(The Words of the Chairman), Harun Farocki, German Federal Republic, 1967, 3'.

Concerning Violence, Göran Hugo Olsson, Sweden, 2014, 84', OV with Spanish subtitles.

Presented by Miguel Fernández Labayen

We propose *looking* at two books: Mao Zedong's *Little Red Book* and *The Wretched of the Earth* by Frantz Fanon. Paper weapons that we will see translated into images. First in *The Words of the Chairman*, a jokey piece of agitprop where Harun Farocki ironically takes seriously the idea that Mao's words could become missiles in the hands of the revolutionary German youth. And also in the more recent *Concerning Violence*, where Göran Olsson scrutinises the machinery of colonialism through a collage that mixes the text of Fanon with images of African anti-colonial struggles shot by Swedish film makers in the 60s and 70s.

25 > 26 NOVEMBER (Friday > Saturday)

INTERNATIONAL SYMPOSIUM:

The Capture of Speech.

Dialogues with the militant cinema archive.

Registration required.

📍 Z Hall

The international symposium *The Capture of Speech* involves a series of critical dialogues between researchers, film makers and artists. We will shake up the militant cinema archive with talks, screenings and performances. We will look at new readings and points of view, we will probe forgotten experiences and unnoticed gestures, we will watch, listen to and discuss the talks that gave meaning to the project of uniting the political struggle and cinematography during the cycle of struggles in 68. A great conversation of words, images and gestures to ask ourselves what remains today of the militant archive.

10, 11 DECEMBER (Saturday, Sunday)

Workshop

Zinetraktatu!

Registration required.

📍 Workshop

During the revolution in May 1968 in Paris, a group of film makers started to produce ciné-tracts, "ciné-pamphlets": anonymous, low-cost audiovisual pieces, produced as fast as possible. An attempt to participate in the frenetic pace of events through cinematic representation. The ciné-tracts were based on a careful reflection on the environment: a duration of 3 minutes (the length of

a roll of film) and a simple structure, based on a succession of short texts and mounted camera stills. The Zinetraktatu! workshop will start from a deliberately anachronistic premise: what would happen if the technical and political precepts of the ciné-tract (speed of execution, brevity, simplicity and communicative effectiveness) were put into practice today, using digital audiovisual technologies?

11 DECEMBER (Sunday)

19:00

Carte Blanche to Stoffel Debuysere

We will close the *Europe, Future Past* season by inviting Stoffel Debuysere to curate and present a session of screenings to reflect on transfers between the militant film archive and contemporary practices. Debuysere is one of the programmers of the Courtisane festival and a lecturer at the KASK School of Arts in Ghent (Belgium).

**SEASON
KOMIKILABEA**

KomikiLabea explores the world of comics and their many aspects from an artistic and creative perspective and also through the language of this art, capable of addressing any topic or theme, used directly or transversally. A project in collaboration with Donostia/San Sebastián 2016 and the culture section of the Diputación Foral de Guipúzcoa. It also has the support of: Donostia Kultura (Semana de Terror and Red Municipal de Bibliotecas), Kutxa Kultur, Kunsthal Centro Superior de Diseño, Kaxilda and

Tabakalera. Through activities such as workshops, conferences, master classes, exhibitions and screenings, two lines of work will be addressed: one related to fiction, with particular attention paid to one of its most widespread and popular genres, which is that related to fantasy; and another more related to non-fiction that promotes critical and reflexive thought in a continuous dialogue with other formats such as essays, journalism and dissemination.

5 NOVEMBER (Saturday)

20:00

Bloody Dairy, Min Liu, Taiwan, USA, 2015, 3', OV with Spanish subtitles.

Seoul Station, Sangho Yeon, South Korea, 2016, 92', OV with Spanish subtitles.

CARTES BLANCHES

It is one of the programme lines of the film theater and it consists on inviting to program a *carte blanche* international film festival to activate our screen.

16 DECEMBER (Friday)

20:00

FEMINISTALDIA 2016 - #PLAZA

Feministaldia is a festival of feminist culture driven by Plazandreak. In its 11th edition, it starts from the term #Plaza with the aim of creating a meeting place, a place from where to make feminist culture public and bring it into the public arena.

Gelén Alcantara, from the Jeleton collective, has been invited to perform an audiovisual programme within the framework of Feministaldia.

KAMALEOIAK GARA! CINEMA

Once a month, the Tabakalera cinema will present an audiovisual programme for all ages (animation, experimental cinema, short films...). After the screening, we will conduct a workshop to work collectively on issues and techniques related to the film.

+ INFO: p 51

6 NOVEMBER (Sunday)
12:00

11 DECEMBER (Sunday)
12:00

7, 8 and 9 OCTOBER
(Friday, Saturday and Sunday)

INTERNATIONAL FILM SEMINAR

Registration required.
Price: 50€ (meals included)

Tabakalera, International Centre for Contemporary Culture presents its First International Film Seminar: three days inside the cinema to watch audiovisual materials and share texts, processes, talks, debates and encounters in one side and the other of the screen. We asked **Javier H. Estrada, Beatriz Leal and Elena López Riera** to draw an itinerary of audiovisual, academic and theoretic references to present the works by the guest filmmaker and artists: **Safia Benhaim, Filipa César, Oliver Laxe, Camilo Restrepo and Vincent Meessen**.

Part of *Conversations*, a programme of DSS2016EU.

PROGRAMME AT TABAKALERA

The Tabakalera hall scheduled for various institutions, agencies, etc.

22 OCTOBER (Saturday)

Meeting DOCUMENTARY FILM AND MEMORY: MEETING WITH PATRICIO GUZMAN

Patricio Guzmán

18:00 ES

📍 Z HALL

Organized by: Cristina Enea Foundation.

Patricio Guzman is one of the most internationally renowned Chilean film makers. After the coup in Chile, he remained in the Estadio Nacional de Santiago, isolated and threatened with execution by firing squad. He left the country in November 1973. He has lived in Cuba, Spain and France, where he currently resides. Six of his works have premiered at Cannes, including: *The Battle of Chile*, *Le Cas Pinochet*, *Salvador Allende* and *Nostalgia for the Light*. With the latter he won the Award for Best Documentary at the European Film Academy Awards in 2010. His latest work *The Pearl Button* won the Silver Bear at Berlin in 2015. He was invited to be part of the Hollywood Academy in 2013 and is the president and founder of the Santiago Documentary Festival, FIDOCs. Recent retrospectives: British Film Institute, Harvard Film Archive.

Screening

20:00

El botón de Nacar (The Pearl Button), Patricio Guzman, Chile, 2015, 82'

With the director.

12 NOVEMBER (Saturday)

GEHITU: SEBASTIANE AWARD

Session organised by Gehitu: Association of lesbians, gays, bisexuals and transgender people in the Basque Country. The Sebastian Award is an award which Gehitu presents in the framework of San Sebastian International Film Festival, which looks for the film in any of the sections of the competition that best reflects the values and reality of lesbians, gays, bisexuals and transsexuals.

The award was created in 2000 with the aim of giving visibility to these films within the Zinemaldia programme.

Nunca vas a estar solo (You'll Never Be Alone), Alex Anwandter, Chile 2016, 82'



PUBLIC PRO- GRAMMES

Public programmes are designed to generate reflection and debate from a series of related activities, in the form of workshops, seminars, presentations, screenings and debates.

Index

THE THREE CIRCULATIONS: ACTIVE SUBSTANCE

- THE THREE CIRCULATIONS: ACTIVE SUBSTANCE
- OUT OF SYNC 2ND ACT
- SMOKE POLITICS

THE LISTENING OBSERVATORY

CITY AND OTHER POLICIES

ARCHITECTURE: FILM LANGUAGES "EUROPE TAKEN"

SISTER OF ANOTHER MAMA

LAPUBLIKA

SOUND CINEMA - CITYSCAPES

FEMINISTALDIA

The Three Circulations
ACTIVE SUBSTANCE



STIMULANTS: CIRCULATION AND EUPHORIA

29, 30 SEPTEMBER, 1 OCTOBER

(Thursday > Saturday)

Seminar

THE THREE CIRCULATIONS “Active Substance”

The seminar *The Three Circulations* is a meeting that seeks to analyse three plans and dimensions of circulation, configured around “active substances”. Despite the fact that the routes that trace the “active substances” are diverse and virtually infinite, it is possible to locate them in three specific dimensions which in turn structure and affect all activity and life on the planet: circulation in the human organism, the global circulation of goods, and, outside the worldly domain, that which we call cosmic circulation. .

29 SEPTEMBER (Thursday)

Presentation + conference

Oier Etxeberria, Pablo Lafuente.

19:00 ES

📍 Z Hall

Conference

UNA, DOS, TRES... CIRCULACIONES

Max Jorge Hinderer Cruz.

19:30 ES

📍 Z Hall

Presentation by the international seminar entitled *The Three Circulations: Active Substance*

and the inaugural conference, in which the main research lines and theoretical perspectives that the meeting will address on stimulants, sensitivity and movement will be recorded.

30 SEPTEMBER (Friday)

Conference

LA LEYENDA DE LA COCA

Jorge Hurtado

17:00 - 19:00 ES

📍 Z Hall

The legend of Coca in Jungian analysis has shown very accurately the reality of the coca plant and its derivatives and has helped to find far-reaching political solutions.

Performance-presentation

INES DOUJAK / JOHN BARKER

19:30 EN + ES

📍 Workshop

What inside forms an outside and what is the space inbetween? We will talk of the substance ergot and one of its alkaloids LSD as freeing consciousness from neuro gatekeepers, of the skin as more than a container, and of disgust as an emotional and political barrier.

1 OCTOBER (Saturday)

Round table

Lorea Alfaro, Erick Beltrán, Ibon Aranberri and Fernando Palma.

11:30 - 14:30 EN + ES

📍 Z Hall

Presentations by artists and panel discussion on the general approaches of the seminar *The Three Circulations: Active Substance*.

Conference

FREEDOM AND SECURITY

Antonio Escotado

19:00 ES

📍 Z Hall

A review of efforts focused on ignoring the substantial identity of both things, freedom and security, from the Inquisition to the revolutionary courts, paying special attention to tobacco.

SMOKE POLITICS

Smoke Politics is a programme that comprises a series of conferences from different dead authors, that will be pronounced, commented, set in stage, by different guest authors throughout 2016.

27 OCTOBER (Thursday)

Conference

RATIONALISATION

Simone Weil by Esteban Zamora

19:00

📍 Z Hall

This is the only talk Simone Weil (Paris, 1909 - Ashford, 1943) gave in life, on 23 February 1937 to a public made up of workers. With her typical sensitivity, the thinker discussed the vicissitudes of a rationalisation process in which while the worker's body is reduced to the status of tool, the products obtained in the process are fuel for a machine that continues to expand its dissatisfaction across the face of the earth. Weil refuses to conceive the oppression exerted on workers only in economic terms and states in her text: “The worker suffers not only from inadequate pay. He suffers because he is overshadowed by today's society to a lower rank, because he is reduced to a form of servitude.”

Esteban Zamora Godoy, graduate Philosophy professor at the Metropolitan University of Educational Sciences UMCE Santiago holds a degree in Philosophy from the ARCIS University of Chile and a Doctorate in Philosophy from the University of Barcelona (UB). He publishes the magazine VÍSCERA and is part of the Kaxilda space/project located in Donostia-San Sebastián.

24 NOVEMBER (Thursday)

MONTECRISTI MANIFESTO

José Martí by Josebe Martínez

19:00

📍 Z Hall

The “Montecristi Manifesto” (25 March, 1895) is the proclamation of the poet, thinker and founder of the Cuban Revolutionary Party, José Martí (Havana, 1853 - Dos Ríos, 1895). It is the declaration of the war of independence of Cuba against Spain (1895-1898). The manifesto also represents a call for the uprising of the Cuban population against the Spanish government, denouncing the persistence of the colonial order and appealing to the national will and for miscegenation.

Josebe Martínez is Professor of Hispanic-American Literature at the University of the Basque Country.

OUT OF SYNC LOUDER, FASTER, STRONGER

In the language of the music, *tempo* is the name given to the speed set for a particular piece of music. The rhythm is the pattern; the *tempo*, by contrast, is the speed, the liveliness. Although most music can be classified according to the speed of the beats generated,



in an age in which time and music are classified for us through digital algorithms, speed has become a very important factor in our musical perception. It reveals the objective, the function. Today we will have the chance to immerse ourselves in the relationships and paradoxes between music and speed, tempo and time

17 NOVEMBER (Thursday)

Presentation
Xabier Erkizia
19:00 ES
📍 Z hall

Listening
EARLY MINIMALISM VOLUME ONE (1964-1965)

Tony Conrad (1940-2016)
19:30 ES
📍 Z hall

Tony Conrad (1940-2016). This composer, film maker and teacher took part in the powerful American cultural movement in the 60s. Although he became popular as a member of the group *The Dream Syndicate*, with people such as La Monte Young, Marian Zazeela and John Cale (The Velvet Underground), he was also active in the New York experimental film circuit and the start of sound art.

18 NOVEMBER (Friday)

Concerts
19:00
📍 Z hall

RAS

Although two decades have passed since this *grindcore* group was founded in Tolosa. It remains one of the reference points for this style of extreme music, both in the Basque Country and in Spain. The group's sound follows the classic basics of the genre, namely, guttural vocals, heavy guitar tones and drums that go at impossible speeds, in search of a deadly and politically charged mixture.

AGNES PÉ

Agnès Pe (Lérida, 1985) works on sound, beyond all limits imposed by musical genres or styles. The humour and endless curiosity that she shows with regard to the sound elements that she re-composes in such a personal manner are the fundamental characteristics of her work. She creates sound strings sewn along giant collage lines made up of thousands of references in a range of fidelities (hi-fi, lo-fi, etc.). The unusual appeals to her. The label is the least important.

19 NOVEMBER (Saturday)

Conference
MUSIC AND SPEED
Miguel Álvarez Fernández
19:00 ES
📍 Z hall

Different strange effects created through the interaction of music and speed will be analysed, rummaging in the varied repertoire of classical music, pop culture and avant-garde music, also looking at sounds that have influenced cinema.

Cinema marathon
GOODBYE TO TIME. CINEMA AND SPEED
00:00
📍 Z hall

In English, the term *flicker* is used to refer to any light phenomenon that causes flashes of light in the eye. The films that we group under this term (*flickering*) are characterised by the high speed and mathematical composition of colours, without any added presentation. This extreme lack of dressing leads us to the origins of cinema, the DNA of the magic of cinema, the deception of our eyes. On the other hand, but similarly revealing the structure of cinema, would be those films which, by limiting the movement of the camera, expand time to excess.

THE LISTENING OBSERVATORY

This project pays attention to the realities that are found in the soundscape and demonstrates many of the hearing problems that affect us. For The Listening Observatory, language is not a communication tool which contains our main sounds but a way of life.

In collaboration with DSS2016EU.

14 OCTOBER (Friday)

Presentation
LISTENING OBSERVATORY
Presentation of the findings of the research project.

José Luis Espejo
19:30
📍 Workshop

José Luis Espejo will present the conclusions of the research project *Listening observatory*, which consisted of a series of interviews conducted in the 18 districts of the city of San Sebastian between the months of January and September 2016. The aim was to collect first-hand information on the perception of the acoustic space and coexistence in the city.

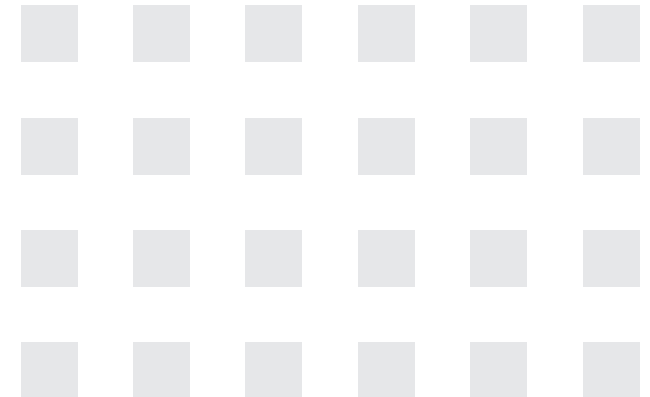



CITY AND OTHER POLICIES

2 > 5 NOVEMBER (Tuesday > Saturday)

Workshop + presentations

LA INSTITUCIÓN EMANCIPADA: TABAKALERA COMO ESCENARIO DE RESISTENCIA

Miguel Mesa del Castillo

Registration required.

📍 Workshop

Can a building be liberated? Can resistance/strength be located in an institution? Historically, architecture has been linked to spatial order, to the idea of attachment, to the hierarchy, delimitation and stabilisation of society. This workshop will try to examine the legitimacy of this interpretation in order to affirm architecture involved in the dynamics of resistance, taking the Tabakalera building itself as a case study.

NOVEMBER

Lectures, screenings and workshops

ARCHITECTURE: FILM LANGUAGES. EUROPE TAKEN

Architecture: Film Languages (AFL) is an annual season of lectures, workshops and screenings that aims to look into one of the major categories of our time: The City.

In a format that alternates between film screenings and workshops, this programme makes it possible to hold a series of meetings with local and

international authors in an attempt to generate a reflective approach to the city, urban policies and geographical territorial analysis from very different places.

In collaboration with Cristina Enea and DSS2016EU.

8 NOVEMBER (Tuesday)

Presentation

TXATAR AROAZ: ALEXANDER KLUGEREN PENTSAERA ETA JARDUNBIDE JAUZILARIEN HARIRA.

Elena Martínez Rubio.

19:00 EU 📍 Z Hall

Screening

Das Kapital (News from Ideological Antiquity - Marx / Eisenstein / The Capital), Alexander Kluge, Germany, 2008, 570'.

20:00 📍 Z Hall

Synopsis: or almost nine hours, Alexander Kluge attempts to reconstruct the unfinished project of Sergei Eisenstein to shoot *Das Kapital* by Karl Marx after a feverish meeting with James Joyce in 1927. It is also an attempt to understand the validity of Marx in our time, to return to the idea of cinema as a means of criticism and knowledge.

9 NOVEMBER (Wednesday)

Meeting

Meeting with Elena Martínez Rubio.

10:00 - 14:00

Registration: cristinaenea@donostia.org

📍 Cristina Enea Foundation

Presentation

POLITICAL ART

Isaías Griñolo and Antonio Orihuela.

19:00 ES 📍 Z Hall

Concert performance

Los Flamencos: Cante tóxico nº III.

20:00 📍 Z Hall

Cantes tóxicos was conceived in 2012, in the manner of the poetry machine in *Juan de Mairena* by Antonio Machado, to sing about, relate and demonstrate the excesses of neo-liberalism. *Cante tóxico nº III* includes traces of the protest and pain of citizens hounded by the rich, the powerful and the politicians, who have hijacked democracy and are denying them a future. Hybrid stories of our times, in the manner of a collage, which swings between the world of poetry, the performance of flamenco, critical discourse and audiovisual production, to show this new social scenario built with and on the suffering of the people.

10 NOVEMBER (Thursday)

Meeting

Meeting with Isaías Griñolo, Niño de Elche and Antonio Orihuela.

10:00 - 14:00 ES

Registration: cristinaenea@donostia.org

📍 Cristina Enea Foundation

Presentation

TOURISMOGRAPHY / BARCELONA - LISBON / THE CULTURAL CAPITALS.

Andrés Antebi and Daniel Malet

19:00 ES 📍 Z Hall

Screening

La piel quemada (Burnt Skin), Josep Maria Forn, 1967, Spain, 110'

20:00 📍 Z Hall

Synopsis: Story about the problem of the mass migration from the most depressed regions of Spain to the most prosperous and developed. In a town on the Costa Brava, a bricklayer starts his working day. At the same time, in an Andalusian town, his wife and their two children start the journey to rejoin him. During the time that he has been alone, the man has had an affair with a Belgian tourist, which has revealed an undreamed of world to him.

11 NOVEMBER (Friday)

Meeting

Meeting with Andrés Antebi and Daniel Malet.

10:00 - 14:00 ES

Registration: cristinaenea@donostia.org

📍 Cristina Enea Foundation

28 NOVEMBER (Monday)

Presentation

PRESENTIST DEMOCRACY. An assessment of this alternative democracy in Europe.

Isabell Lorey.

19:00 ES/GER 📍 Z Hall

Screening

Haremakono, Abderrahmane Sissako, Mauritania, 2002. 95'.

20:00 📍 Z Hall

Synopsis: The values of democracy are currently being defended in Europe by fighting against its enemies in wars to reinforce the State. Liberal democracy





has drained of any content, form or notion that it cannot use to legitimise itself. However this lack of form reveals an authoritarian government that is responding to a state of emergency and social insecurity.

29 NOVEMBER (Tuesday)

Meeting

Meeting with *Isabell Lorey*

10:00 - 13:00

Registration: cristinaenea@donostia.org

📍 Cristina Enea Foundation

SISTER OF ANOTHER MAMA

1 OCTOBER (Saturday)

Performance + publication

CORNERS OF EUROPE

Mila Pavicevic, Joseba Irazoki, SIMKA - Simon Häggblom, Karin Lind

19:00 📍 Nestor Basterretxea Square

By setting a temporary editorial space artists will reach out to and interact with audiences through artistic interventions and in collaboration with the local community. Together they will create their own newspapers. A project with DSS216EU.

LAPUBLIKA

28 OCTOBER (Friday)

Live radio programme

RADIO SYMPOSIUM LAPUBLIKA

+ Info and tickets: www.lapublika.org

📍 Patio, Z hall and othe spaces of Tabakalera

Following on from the 2015 edition, this year's LaPublika will take the format of an international radio-

symposium taking place in Donostia / San Sebastian on 28th October 2016: 15 hours of live broadcast open to the public with conversations, music, performances, sound installations, activities in the city and with international connections.

LaPublika is a project directed and coordinated by *consonni*, produced by San Sebastian 2016, European Capital of Culture and Tabakalera International Centre for Contemporary Culture with the collaboration of the Faculty of Fine Arts of the UPV/EHU, Azkuna Zentroa, Filmin and Dabadaba and the support of Hotel Silken Amara Plaza, Bilbao Ekintza, EHUKultura (Directorate of Event Programming and University Promotion Bizkaia, UPV/EHU), Regional Council of Bizkaia, EITB, Casares Radio, 97 FM Radio, Radio Euskadi, Vallekas Radio, Spain's Public Agency for Cultural Action (AC/E), Fabricas de la Creación de Gobierno Vasco, TEA FM School Radio.

DAY PROGRAMME

Conversations

Rosalyn Deutsche in conversation with *Jaime Iregui*.

Mutamassik (Giulia Loli) in conversation with *Michelle Teran and Elvira Dyangani Ose*.

What, How & for Whom/WHW in conversation with *Daniel G. Andújar.El Niño de Elche* in conversation with *Belén Gopegui*.

10:00 - 13:00

📍 Tabakalera

Performances, Artistic Interventions and Concerts:

Sra. Polaraiska, Rosa Casado and Mike Brookes, Daniel G. Andújar, Okela, Sangre

Fucsia, PCAP /Akbild Vienna, Oier Iurretagoiena, Societat Doctor Alonso and Moaré Danza, Mugatxoan, grupo de investigación Orea* and Aziza Brahim.*
10:00 - 13:00
📍 Tabakalera

Programme anchored by *Alicia San Juan*.
Edited by *Alberto de la Hoz*.

Free access.

NIGHT PROGRAMME

Concerts

Los Torreznos: "La realidad" (2016), Mutamassik and Tremenda Jauria.

21:00

📍 Dabadaba, Mundaitz Kalea, 8, 20012 San Sebastián

SOUND CINEMA - CITYSCAPES

3 DECEMBER (Saturday)

Installation

18:00 - Wrocław

19:30 - Basque Cities Sound Portrait

4 DICIEMBRE (Sunday)

Installation

18:00 - PICTURES OF WARSAW

19:30 - CITYSCAPE KRAKÓW

The Musica Electronica Nova festival launched the *Sound Cinema* Project in the city of Wrocław in March 2016. Due to the fact that various European composers have been invited to create sound images of different cities and countries, on this occasion we'll have the opportunity to see an electro-acoustic portrait of these Polish and Basque cities at Tabakalera.

FEMINISTALDIA

14 > 17 DECEMBER

(Wednesday > Saturday)

FEMINISTALDIA 2016

Meeting

By Plazandreok.

Guest: Gelén Alcántara, Onintza Enbeita, Silvia Federici, Jule Goikoetxea, Maialen Lujanbio

Feministaldia is a festival of feminist culture driven by Plazandreok. In its 11th edition, it starts from the term #Plaza with the aim of creating a meeting place, a place from where to make feminist culture public and bring it into the public area.



HIRIKI- LABS

**HIRIKILABS. DIGITAL CULTURE AND TECHNOLOGY
LABORATORY.**

Project created in collaboration between
Tabakalera and Donostia / San Sebastián 2016
European Capital of Culture

Index

HIRIKIKAS

- TECNO LABS WORKSHOPS
- GENERATIVE NATURE

HIRIKILABS PLAZA

JOLABS

- DO IT IN FAMILY
- WORKSHOP

MEETINGS

- FREE SOFTWARE AND TECHNOLOGY
- EGINZALEAK!

HIRIKIKAS

5 OCTOBER (Wednesday)

Workshop

INTRODUCTION TO DIGITAL MANUFACTURING: 3D PRINTING

17:00 - 20:00 ES

Registration required.

📍 Hirikilabs

3D printing consists of manufacturing three-dimensional solid objects by adding material, layer by layer, from a computer-created digital model. The learning session includes managing and programming 3D printers based on open-source hardware.

SEASON: GENERATIVE NATURE

During this season, we are putting on a series of workshops and processes about parametric and generative programming for digital creation and manufacturing. Inspired by the behaviour of nature: **Biomimetics**

4, 11, 18, 25 OCTOBER

22, 29 NOVEMBER (Tuesday)

Workshop

OPEN FURNITURE DESIGN: EXPERIMENTING WITH MATERIALS AND SHAPES

Arquimaña

17:00 - 20:00 ES

Registration required.

📍 Hirikilabs

Following the open furniture design process initiated with the launch of Hirikilabs in 2013 and revived by moving into the Tabakalera building between September and December

2015, this year we will resume the process, with the objective of creating a set of furniture that can be put in the public areas of the building.

19, 26 OCTOBER (Wednesday)

Workshop

ALGORITHMIC NATURE

Jaime de los Ríos

17:00 - 20:00 ES

Registration required.

📍 Hirikilabs

Through a series of parametric applications carried out in the VVVV visual programming language, we will study the basics of the most common equations in the natural world: Particle systems, patterns, fractals, group behaviour, voronoidal generative construction ... to combine it with external elements, such as sound or light, and generate different algorithmic designs for 2D and 3D printing.

29 OCTOBER (Saturday)

Workshop

MAPATHON: MISSING MAPS

Missing Maps, Médicos Sin Fronteras

17:00 - 21:00 ES

📍 Hirikilabs

Missing Maps is an open, collaborative project that aims to create a cartography of the most vulnerable places in the developing world, so that local and international non-governmental organisations, aid workers and local people can use the maps and data to respond better to crises that affect these areas.

15, 16 NOVEMBER (Tuesday, Wednesday)

Workshop

WORKSHOP ON PARAMETRIC DESIGN AND MANUFACTURING IN PAPER WITH VVVV

Aristides García

17:00 - 20:00 ES

Registration required.

📍 Hirikilabs

This 2-day workshop is focused on developing tools inspired by architecture and industrial design, with the aim of making three-dimensional modular parts in paper and cardboard. Aimed at anyone interested in geometric patterns, architecture, set design and 3D Mapping.

8, 9, 23 NOVEMBER (Tuesday, Wednesday)

Workshop

EXPERIMENTAL WORKSHOP ON GENERATIVE DESIGN AND NATURAL PATTERNS

Maria Mallo

17:00 - 20:00 ES

Registration required.

📍 Hirikilabs

This workshop is based on collaborative work and learning models through action. The general theme revolves around generative design, digital manufacturing, natural patterns, complex geometries, reactive structures and interaction with users. The specific objectives of the group will be set in the first two days of the workshop, based on the interests of the participants. We will work by creating prototypes through digital manufacturing, also using the standard materials in this field (wood and plastics) and others that allow greater adaptability, such as latex or silicone. The end result of the workshop is open, covering anything from experimental models to product design applications, architecture and art installations.

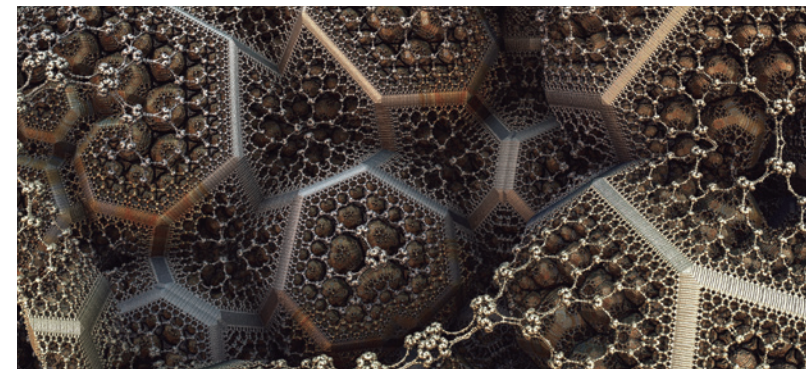

Algorithmic Nature

HIRIKILABS PLAZA

OCTOBER, NOVEMBER, DECEMBER
(Every Thursday)

Meeting

HIRIKILABS PLAZA 6.

Work sessions to develop projects for the 6th call

16.00 - 20.00

📍 Hirikilabs

Hirikilabs-Plaza is a place for meeting and developing projects that are constructed from collaboration between people, groups and communities well-versed in the field. A moment in which to be able to meet other people and investigate, share and use the Hirikilabs space, equipment and / or resources in an open workshop format, to make creative ideas evolving from DIY (do it yourself) to DIWO (do it with others) a reality.

JOLABS

1, 8, 15, 22, 29 OCTOBER (Saturday)

5, 12, 19, 26 NOVEMBER (Saturday)

3, 10 DECEMBER (Saturday)

Workshop

JOLABS. DO IT IN FAMILY

10:00 - 13:00 EU

Registration required.

📍 Hirikilabs

Joblab sessions on Saturdays will become a three month process. Rather than holding more structured workshops, we will work on projects, in a freer format. Both children and their families will take part In this process and, between us all, we will define those projects that we are

going to develop. We will meet every Saturday to work in a free workshop format, developing creativity and cooperative learning.

5 NOVEMBER (Saturday)

Workshop

EFFICIENT CREATION OF TEMPLATES

Maria Mallo

10:00 - 13:00 ES

Age: 7-12

Registration required.

📍 Hirikilabs

Starting with natural shapes, we will make templates for use in drawings/ design, so that we can later imagine what cities and towns, cars or everyday objects would be like if, instead of having straight angles, they had natural shapes.

MEETINGS

17 NOVEMBER (thursday)

Meeting

EMPOWERING TECHNOLOGY. FREE SOFTWARE AND TECHNOLOGY MEETINGS

09:30 - 20:00

📍 Hirikilabs

The aim of this meeting is to activate a space in which to display free technologies, in order to trigger discussions and initiatives. Among the subjects we intend to touch on are: free data, open source standards, open source hardware, open source infrastructures...

This meeting is a Talaios and UEU project.

13 > 17 DECEMBER (Tuesday > Saturday)

Meeting

EGINZALEAK ! 4TH CITIZEN TECHNOLOGY AND MANUFACTURING WEEK

A week for learning and sharing that will conclude in a fair, in which we can show and find out more about open, collaborative citizen projects

13 > 16 DECEMBER (Tuesday > Saturday)

FASHION AND TECHNOLOGY WORKSHOPS

17:00 - 20:00

Registration required.

11 DECEMBER (Saturday)

FAIR

10:00-14:00 / 16:00-20:00

Presentation of the projects at:
www.tabakalera.eu



Eginzaleak!#3

EDUCA- TION



KAMALEOIAK GARA!

Index

KAMALEOIAK GARA!

- PROGRAMME
- EXHIBITION
- WHERE DOES CHOCOLATE COME FROM?
- CINEMA

HIRIA HACHEATU

ESPACE 0-6

ZOOM. VIDEO LABORATORY

FEMINIST STRATEGIES IN EDUCATION. FEMINISTALDIA

COMMUNITY-EDUCATION

- WALKS-WORKSHOP
- ELKAR-EKIN, MEDIUM-TERM PROGRAMMES
- SCHOOL PERIPHERIES

PROGRAMME WITH TEACHERS

KAMALEOIAK GARA!

Kamaleoiak gara! is an activity programme for children and adults to enjoy together in the framework of contemporary art. Mothers with children, parents with nieces, grandchildren with grandmothers... who want to come to Tabakalera together, share knowledge and learn within an intergenerational community.

OCTOBER 8 , NOVEMBER 12 (Saturday)

KAMALEOIAK GARA! PROGRAMA! 0-99

17:00

Registration required.

📍 Sala Z

8 October

Circus

IRAKURRIZ

Shakti Olaizola

We immerse ourselves into the somewhat peculiar world of a girl. As she reads, she takes us through the different chapters of a story full of memories, discoveries, reflections, dreams... From the situations and objects she encounters along the way, she reveals and shares their stories with us.

Everyday actions and objects become a game, a challenge and a delight with movement, sound, balancing, dancing and contortion. How will this journey end?

November 12

Theatre

KUBIK

Cía. Teatro Paraíso

The show is inspired by the games of children who physically experience their environment in order to understand it.

By manipulating objects within their reach, they build their thoughts and open the door to their imagination. In *Kubik*, two actors manipulate a giant set of constructions, that are piled up and transform, moving and generating new spaces to explore. It is architecture in motion, in which volumes and forms create small mobile screens on which images are created.

OCTOBER 23 , NOVEMBER 27,

18 DECEMBER (Sunday)

Workshop

KAMALEOIAK GARA!

EXPOSICIÓN 5-99

11:00 - 12:30 EU

Registration required.

Thorough these workshops, we propose to play with, discover, take part and dynamically activate the pieces of art, objects and discourses in the rooms.

OCTOBER 1 , NOVEMBER 19 (Sunday)

Workshop

KAMALEOIAK GARA!

WHERE DOES YOUR BREAKFAST COME FROM?

11:00 - 12:30 EU

Registration required.

As part of the *Stimulants: circulation and euphoria* programme, in this workshop we will analyse the food we eat in order to learn about its origin, consumption, distribution and method of production from the pieces and processes that we will find throughout the exhibition. We will explore the cultivation areas experiment with plants, fruit and seeds and we will even invent new recipes.

October 1

WHERE DOES CHOCOLATE COME FROM?

All, or nearly all, of us have tried chocolate at some time and we love it! But... how many times have we thought about the origin of chocolate, the form of the cocoa plant and its fruit?... Exploring and experimenting with chocolate, melting it, heating it up and giving it new forms, eating and painting with chocolate...these are some of the things that we will do in this workshop.

November 19

JELLY MINI-CUPS

How are jelly mini-cups made and what are their components? Would we be able to make our own home-made sweets? What if we also try to do so without sugar and using organic fruit? In this workshop we set you the task of getting the ingredients, preparing, cooking, shaping, testing and enjoying making healthy sweets.

NOVEMBER 6, DECEMBER 11 (sunday)

Workshop

KAMALEOIAK GARA!

CINEMA 5-99

With Aitor Gametxo

Screening 12:00

Workshop 12:45 EU

Registration required.

During the next school year, we propose stabilising the *Kamaleoiak Gara!* Cinema programme and enabling intergenerational meetings with experimental audiovisuals, in harmony with our *Education and audiovisual narratives* line of work. Understanding that cinema has a significant educational potential, we propose a session of short films at the Tabakalera cinema and a workshop afterwards will work on topics and techniques arising from the viewing.



ELKAR-EKIN

OCTOBER 28 , NOVEMBER 25 (Friday)
DECEMBER 27 > 30 (Tuesday > Friday)

Work group

HIRIA HACKEATU
Young people, the city and makers

October 28, November 25 **17:00 - 19:00 EU**
 December 27-30. **10:00 - 14:00**
 Age: 12 -17 years old.
 Registration required.

Casting a glance at public spaces from the perspective of young people and rethinking the ways of adapting these spaces to their needs is the main objective of Hiria Hackeatu.

In addition to the intensive workshops that we run in summer periods, during this school year, we will meet on the last Friday of every month to carry out activities arising from the interests of the group. In this way, the issue of the intensive workshop in December will be proposed during previous sessions.

Work group

SPACE 0-6

Proposal for developing a project for families with children from 0 to 6 years old, where they can design, collectively build and develop practices of joint learning, workshops and education processes related to contemporary cultural practices. The aim is to investigate and generate other art education models at an infant level and alternative ways of designing and constructing spaces. We began the design process in May and, in the coming months, in addition

to continuing this process, we will start the construction of a reproducible device which can be dismantled, so that it can be deployed and set up in various spaces in Tabakalera. We will build different elements of Space 0-6 using the Hirikilabs workshops.

OCTOBER 28, NOVEMBER 4 (Friday)

Workshop

BUILDING SPACE 0-6: SOFT FURNITURE

Oihana Legorburu. Haria Slow Fashion
17:30 - 19:30

Registration required.
 ♣ Hirikilabs

Soft, smooth furniture is essential in a space for children of 0-6 years of age: cushions, carpets, pouffes... We will build some of these elements in two practical workshops, while we learn to use a sewing machine and concepts of pattern designing.

NOVEMBER 30, DECEMBER 1

(Wednesday > Thursday)

Workshop

BUILDING SPACE 0-6: SENSORY INSTALLATION

Paola Guimerans
17:30 - 19:30

♣ Hirikilabs

Touch, hearing, sight... the stimuli that they receive at this age are important for developing the senses. We will create an interactive installation for Space 0-6 using different materials, e-textiles, light, sound, etc., so that children have an interactive toy equipped with various sensors.

2016 > 2017

Workshop-Work group

ZOOM. VIDEO LABORATORY

Age:16-21 years old
 Registration required.

Are you between 16 and 21 years of age? Are you interested in cinema and the audiovisual? How many times have you quoted dialogues and scenes from films? Do you want to share these interests with other young people of your age?

Zoom is a group made up of young people aged between 16 and 21 who are interested in the audiovisual. We believe that this is a key age in the development and expression of ways of self-representation which largely come from the field of video, imagery and sound. In this way, based on the interest and specific needs of the young people, during the 2015/16 school year we prepared schedules for the cinema, took part in workshops with artists such as Antonio Macarro and Jaume Ferrere, made swaps and trips with the young people from the CA2M *SUB21 team*, seen and produced audiovisual material... had a few laughs and created a group.

For the 2016/17 year, we are calling you to join us. The first run out will be at the workshop on October 22, which is when we will introduce ourselves and get to know each other better.

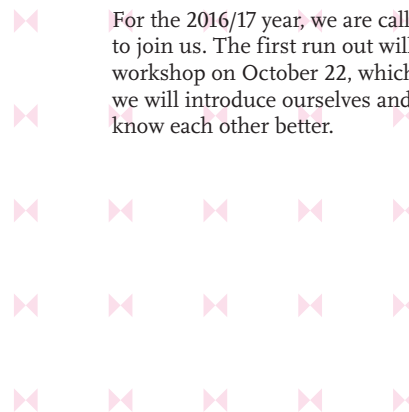

DECEMBER 12 > 13 (Monday > Tuesday)

Workshop

FEMINIST STRATEGIES IN EDUCATION. FEMINISTALDIA

In December, we will take part at Feministaldia 2016, like we did at the 2014 and 2015 editions, continuing the line on feminist education. In this framework, we aim to resume the programme that took place in July 2016 with teachers, focused on looking at feminist strategies in education. Based on the interest that this programme generated, we propose forming a group made up of teachers to discuss, reflect on and investigate feminism and pedagogy.

COMMUNITY EDUCATION

Programmes aimed at schools, associations and training groups.

2016/2017 SCHOOL YEAR

(From Wednesday to Friday)

Workshops for groups

WALKS-WORKSHOP

10:00 -14:00 / 16:00 - 18:00

We will specify the schedule at the time of booking. Duration: 2 hours.Registration required.

Aimed at schools and associations

Walks-workshops allow an introduction to Tabakalera. They are proactive sessions in which we adapt to the needs and interests of the groups and seek their active participation.

EXPLORING TABAKALERA!

Workshop aimed at primary school groups.

A tour through different areas of the building goes into further detail about the use and perception of the public space, as well as on the ways in which we operate and live in the everyday places. Through different dynamics and games, this workshop aims to transform the Tabakalera spaces with the aim of thinking about their collective use.

LIVING ORGANISMS

Aimed at groups of primary school, secondary school and high school students and associations.

The Living Organisms workshop comes within the framework of the Agency of Living Organisms exhibition. Based on ideas as ways in which networks and systems are articulated in both science and art, we will work with dynamics of performance, living sculpture and the plasticity of materials.

REC: EXPERIMENTAL CINEMA

With Aitor Gametxo

Cinema workshop aimed at groups of secondary and high school students.

By means of this workshop, we propose drawing on the resources of the Tabakalera experimental cinema. We envisage a selection of materials that will lead us to reflect on ways in which the audiovisual builds identities and, in addition, we will provide the framework for finding and proposing alternative visual arts to the mainstream. The workshop will be accompanied by a small practical part.

This workshop will take place between November 2016 and March 2017.

MAÑANA GOODBYE. A GROUP OF WOMEN WORKING TOGETHER

Workshop aimed at groups from associations and adults.

The workshop is inspired by *Mañana Goodbye*, an audiovisual installation in the Storage at Tabakalera. Using materials drawn from this project, we will conduct a series of dynamics and games that will lead us to reflect on notions such as work, memory and history.

Workshops for groups

ELKAR-EKIN MEDIUM-TERM PROGRAMMES

Aimed at educational centres and associations in the Donostialdea area.

During the school year / Dates and times: To be defined with the person in charge of the group.

Duration: 3.-5 work sessions. *(The duration of visits to Tabakalera will be 2 hours, while work in the classroom will be adapted to the scheduling needs of each group).*

The medium-term programme Elkar-Ekin is designed and developed in collaboration with various groups in the educational community.

There is no specific topic or topic which has been closed in advance. We will be looking for a balance between the particular needs of the group and the Tabakalera cultural programme. Thus, the curriculum, subjects or specific interest will be combined with artistic practices and the jointly-designed educational methodology.

OCTOBER > 21 (friday) SCHOOL PERIPHERIES

Call
Aimed at schools of Donostialdea.

Terms of the call and registration: www.tabakalera.eu. Deadline for submitting proposals October 21
Dates: 2015-16 school year

School Peripheries is an annual call to develop a collaborative art and education project in spaces in the school, district or city. It is presented as an opportunity to rethink ways of working and set in motion learning processes that strengthen the educational community. + Info: Education programme or www.tabakalera.eu

PROGRAMME WITH TEACHERS

This programme is a series of meetings in which to share knowledge and experiences between teachers and the Tabakalera education team. We look at these meetings as spaces for generating joint learning processes, finding out current needs and interests and enabling open educational tools. For this reason, we are proposing a framework for dialogue between education and contemporary culture..

Throughout the school year, there will be three seminars in which to investigate common content and methodologies.

OCTOBER 15 (Saturday) MEETING 1: SCHOOL LABORATORY: CO-CREATING OUR SPACE 09:30 - 17:00

Organised in collaboration with Ttipi Studio. Guests: Susana Gimber (Escuela Dovella), Mercedes Álvarez (CA2M), Ttipi Studioa (Ane Abarrategi and Maddi Texeiro), Josu Elortegi (San Nicolás Ikastola) and Jakintza ikastola (management).
Registration required.

Aimed at people interested in education, participation, artistic practices and architecture.

Through this meeting, we aim to reflect on collaborative projects of artistic practices developed in common spaces in schools, taking into account the relationships that are generated between various external agents and school communities. We will learn about various experiences and provide a framework in which to take a critical look at them.

UBIK

Tabakalera's Creation Library

Index

THINKING
AUDIOVISUALS
SOUND
DESKTOP PUBLISHING
VIDEO GAMES
TECHNOLOGY
SPACES AND ARCHITECTURE
OTHERS

Ubik. Opening hours:

From Tuesday to Saturday: 10:00 - 14:00, 16:00 - 20:00
Sunday and holidays: 10:00 - 14:00



THINKING

OCTOBER 1, NOVEMBER 5, DECEMBER 3
(First Saturday of the month)

Meeting

SALTO. FAMILY CONVERSATIONS

Ainhoa Artxanko and Amaia Urzain

17:00 - 18:30 EU / Age: +6

📍 Ubik, Workshop

Instructions for SALTO:

Open your eyes.

Uncover your ears.

Get ready to see, hear and enjoy new experiences.

Are all of your senses awake?

Be strong and ... SALTO! (jump)

We will share family moments to do, talk about, listen, create and, therefore, think about topical issues. By exploring the different resources that the Ubik creation library offers us for young and old, we will enjoy new, different experiences. Salto is also an area to strengthen family relationships.

Each session is unique. Are you going to miss out?

13 OCTOBER, 17 NOVEMBER,
15 DECEMBER (Thursday)

Presentation

KNOTS. STIMULANTS: CIRCULATION AND EUPHORIA

18:30-19:30 EU + ES

📍 Ubik, Hall

In the framework of the project *Stimulants: circulation and euphoria*, this programme seeks to enable reflection, taking the very idea of stimulants as its axis from a botanical, neuroplastic, material and aesthetic perspective. This time, the guests invited to the

Knots sessions will propose five new acquisitions for Ubik funds, making a public presentation in which they will argue the path - the knot - followed.

October 13 -- *Jakoba Errekondo*

November 17 -- *Idoia Castillo Arbaiza*

December 15 -- *Koldo Salinas and Sole Agirre*

29 OCTOBER, 26 NOVEMBER,

17 DECEMBER (Last Saturday of the month)

Meeting

OUTLINE. CRITICAL THINKING

Martxel Mariskal

11:30 - 13:30 EU + ES / Age: +15

Registration required.

📍 Ubik, Living Room

“The postmodern human is moving in a schizophrenic dance, even though frequently not conscious of it, and frequently not wanting to be conscious of it: What is real? Where is the privacy? Where is the power? Who defines our tastes? Is our identity at risk? Can we handle so much complexity? What use do we make of the media, how do they use us? What is happening to our minds? Does our critical capacity weaken? Does our language diminish? Shall we follow the white rabbit? Schizophrenia and tiredness but huge smiles. Survival of the fittest! STOP”.

OCTOBER, NOVEMBER, DECEMBER
(Every Friday)

Meeting

CHECKMATE! BOARD GAMES EVENING

Iñaki Vazquez

18:00-20:00 EU + ES

📍 Ubik, Workshop

Is there any better way to finish off the week? Friday evening is the time to play board games at Ubik.

You will have the opportunity to try out several different games: some work your tactical or strategic reasoning, others your coordination, manual dexterity or memory and there are even those based on chance. Dice, chips, cards, role play and chess are just some of the things that will be used at the table. Don't miss your turn!

AUDIOVISUALS

15 and 29 OCTOBER, 12 and 26
NOVEMBER (Saturday)

Workshop

SELFIE. SESSIONS TO IMPROVE YOUR SELFIES

Niko Iturralde

17:30 - 19:30 EU + ES / Age: +14

📍 Ubik, Workshop

I get my mobile, look for the camera, select the self-portrait option, choose my best profile and click!! Cool! I upload it to my networks for everyone to see.

If you want to take selfies and take part in the best social networks, we will get together at Ubik to practise, share tips and look at a lot of photos. Bring loads of megabytes, you'll need them!

21 OCTOBER, 18 NOVEMBER,
16 DECEMBER (Third Friday of the month)

Meeting

VIDEO KILLED THE RADIO STAR

Itziar Orbegozo

17:00 - 19:00 EU + ES / Age: +16

Registration required.

📍 Ubik

Since MTV broadcast the first video clip in 1981, we have been able to see

different songs, creators, directors, techniques and formats. We can relive different moments of our life through these films: classics, contemporary, in black and white, pioneers, analogue, digital, experimental, modest... All styles fit in these small audiovisual works.

Do you like video clips? If you want to watch, enjoy, analyse, and experiment, this is the place for you! Let's get rocked!

18 OCTOBER, 15 NOVEMBER,
20 DECEMBER (Third Tuesday of the month)

Meeting

EXPERIMENTAL SCREEN

Aitor Gametxo

18:30 - 20:00 EU + ES / Age: +16

Registration required.

📍 Ubik, Experimental screen.

Experimental film brings together some of the most varied film making practices under this threatening term. Despite the differences, the exaltation of form, remoteness from the commercial circuit, its experimental nature and rejection of conventional narrative are, among others, some of the features that films that are considered experimental share.

Experimental Screen is a meeting point for these particular views, with the intention of bringing the public closer to this type of material. A way, not just to understand but to experience experimental cinema.

SOUND

8, 22 OCTOBER, 5, 19 NOVEMBER

(Saturday)

Workshop

I WANT TO BE A DJ!

Las Marines DJ

17:30 - 19:30 EU + ES / Age: +14 years

📍 Ubik, Workshop

Beat, chop, jingle, LP, scratching... If you want to become a DJ, in this workshop you will come across these and more words, choosing discs, mixing tracks and creating effects. The most far-out tables in the room!

DESKTOP PUBLISHING

20 OCTOBER (Thursday)

Workshop

FANZINEMANIA!

Manuel Valencia, 2000 Maniacos

18:00 - 19:30 ES

📍 Ubik, Desktop publishing area

How to put together an underground fanzine? To start to savour *Horror and Fantasy Film Week*, we have organised a masterclass with Manuel Valencia, head of the fanzine *2000 Maniacos*. He will give us hints & tips to help us prepare a publication while the festival is on and submit it at the Guerra de Fanzines (War of the Fanzines).

Fanzine fans and fantasy and horror film addicts, get ready for the fight!

Workshop in collaboration with the San Sebastian *Horror and Fantasy Film Festival*.

26 OCTOBER, 23 NOVEMBER,

28 DECEMBER (Last Wednesday of every month)

Meeting

ATLAS. DESKTOP PUBLISHING MEETINGS

18:30 - 20:00 EU + ES

📍 Ubik, Desktop publishing area

At *Atlas* meetings we share knowledge, criticisms and opinions on the desktop publishing creative process. The intention is to publicise and promote different areas: fanzine collections, design, illustration... This is your opportunity to learn more about the world of desktop publishing.

26 October -- "Social networks" of the 1960s. Koldo Tapia

At this *Atlas* session, we will analyse the network of social relationships that was developed in the 1960s. On par with the networks that broadcast and took care of the Franco regime, a whole social network was built up in barely legal, dangerous, secret ways that got to be very influential.

We will try to teach and put into practice material from that time, leaflets, posters, information sheets etc., showing what the work processes were like and their impact.

23 November -- Meeting with zines in the area, a mobile library of fanzine desktop publishing. Zines of the zone.

In the November *Atlas* session, we will get to know the members of Zines of the zone. Leaving laziness aside, they got their van, designed a contraption as an exhibitor and took to the road on a road trip to show their collection. After visiting many towns

on this tour that began in 2014, they reached San Sebastian to present their project and their collection. Do you want to get to know them?

28 December -- 2016 Fanzine II. Closure of the European Capital of Culture.

ANTEspacio

We started the year with DSS2016EU and we even did its fanzine. With the European Capital of Culture coming to an end, we will take the fanzine collective that we built in January as a starting point, analysing changes, alterations and the consequences that it has generated; reflections, feelings, experiences... What has 2016 brought us? What you want to say about it?

22, 23, 24 NOVEMBER (Tuesday >Thursday)

Presentation

EXHIBITION OF THE ZINES OF THE ZONE COLLECTION

Zines of the zone

10:00 - 14:00 / 16:00 - 20:00

📍 Ubik, Desktop publishing area

In addition to having them at the *Atlas* session, where they will tell us how their project was born, for three days we will be able to take a closer look at the collection of desktop publishing photography that they have been assembling since 2014. The exhibition will be available to anyone who wants to know new publications and even wants to be part of the collection.

If you have desktop publishing photography that you want to be part of the Zines of the zone collection, bring it to the Atlas session on November 23 or send it to Ubik by post before November 20 (Att: Ubik, Zines of the zone. Plaza de las Cigarreras 1, 20012 Donostia-San Sebastián).

7, 8, 9 DECEMBER (Wednesday > Friday)

Workshop

MEETINGS ON THE ARTIST'S BOOK

Milimbo

EU + ES

Registration required.

📍 Ubik, Desktop publishing area



I WANT TO BE A DJ!

For the second year, we are taking part in meetings on the Artist's Book together with arteliburu21, Koldo Mitxelena Kulturunea, The San Telmo Museum and Arteko Taller.

The workshops that we will organise at Ubik will be boosted by Milimbo. The graphic studio and publisher from Valencia tells stories through images. They will provide us with workshops on illustrated books for children, families, and adults. Books are coming to be read with eyes wide open!

7 December
17:30 - 19:00 Wednesday at Ubik: Milimbo
6-10 years old

8 December
11:00 - 13:00 Workshop for adults.
+18 years old

9 December
11:00 - 13:00 Workshop for adults.
+50 years old
17:30 - 19:00 Taller para jóvenes.
11-16 years old

VIDEO GAMES

11, 25 OCTOBER, 8, 22 NOVEMBER, 13, 27 DECEMBER (Second and fourth Tuesday of the month)

Meeting
I ALSO WANT!
11:00 - 12:30 EU + ES / Age: +50
📍 Ubik, Video games corner

Who said that video games were for young people? There are no age limits for playing, trying, testing and enjoying. Come and discover the world of video games.

22 OCTOBER (Saturday)
Presentation
SELECTION OF VIDEO GAMES BY LARA SÁNCHEZ COTERÓN
Lara Sánchez Coterón
18:00 - 19:30 ES
📍 Ubik, Workshop

We have invited Lara Sanchez Coterón, an expert in art and video games, to curate a selection of video games that we will include in Ubik in October. What was your selection based on? What titles do you think are essential? Do you dare to try them?

TECHNOLOGY

4 OCTOBER, 8 NOVEMBER, 13 DECEMBER (Tuesday)

Meeting
NELL'S SCHOOL. TRAINING WORKSHOP ON MANAGING TECHNOLOGIES AND THE INTERNET
Gorka Julio
18:00-20:00 EU
Registration required.
📍 Ubik, Workshop

At *Nell's school* meetings, we look at training on managing technologies and the internet, dominating the resources that they offer us and overcoming the problems that they present us. Every month, we will work on different subjects through theoretical-practical-participatory workshops:

4 October -- Free licenses
Creative Commons, free licenses, Copyright... What are they? How do we use them?
Where can we find images, sounds, videos and content with free licenses that we can use? In this workshop we will learn all of this and much more.

8 November -- Free Software and Hardware
What is the free software? Is it reliable? How can we take advantage? Is freeware the same as free software? And what about free hardware? What is its place within the philosophy of free software? You have the opportunity to find out all about this in the *Nell's school* session.

13 December -- Basics of programming
If when we learn to read we also learn to write, why do we not learn to program when we began to use programs? In this *Nell's school* session, we will learn the basics of programming and discover tools that will enable us to keep programming.

5, 12, 19, 26 NOVEMBER (Saturday)
Workshop
GETTING TO KNOW ARDUINO
Unai Gorrotxategi Sabino
11:00-13:00 EU + ES / Age: +18
Registration required.
📍 Ubik, Workshop

If we had the opportunity to create a device or a robot, what functions and skills would we include in it? We have Arduino programmable chips are at our disposal. You can also program them: an umbrella that forecasts the weather, smart allotments, home automation management systems for a house... We are going to create something with hardware, software and our imagination.

SPACES AND ARCHITECTURE

OCTOBER, NOVEMBER, DECEMBER (Every Tuesday)
Workshop
YOUNG ARCHITECTS CLUB
La Casa del Vacío
17:30 - 19:30 EU + EN / Age: 11-16 years old
Registration required.
📍 Ubik, Workshop

Young Architects Club is a test laboratory for young people to carry out architecture and urban design projects, working on concepts such as three dimensions, layout, volume and geometry. By using representative examples and trial and error exercises, participants will be able to draw, create and build different structures freely and independently, promoting creativity and group work.

The workshops will take place in Basque and English.

OTHERS

OCTOBER, NOVEMBER, DECEMBER (Every Wednesday)
Workshop
WEDNESDAY AT UBIK
17:30-19:00 EU / Age: 6-10
Registration required.
📍 Ubik, Workshop

Every Wednesday we will hold workshops that stimulate topics of Ubik, creation library of Tabakalera. Aimed at children, it will boost creation and be time spent in a fun way.

8 OCTOBER, 12 NOVEMBER, 10 DECEMBER (Second Saturday of the month)
Workshop
HORKONPON. REPAIR WORKSHOP
10:00 - 14:00 EU + ES
📍 Ubik, Workshop

The aim of the HorKonpon workshop is to help make citizens more independent (do it yourself) and share their knowledge. It centres around the repair and re-use of tools we use in our everyday life and encourages team work (do it together).

Bring your broken gadgets and devices and repair them with us!

This activity is being organised in collaboration with DSS2016EU.

20 OCTOBER (Thursday)

Presentation

HUMAN LIBRARY

11:00 - 13:00 EU + ES

📍 Ubik, desktop publishing area

The *Human Library* focuses on people and relationships that come about through their experiences, expertise and knowledge. Through crossover conversations, the protagonists will share their life stories and interests with the participants by promoting dialogue and relationships.

In collaboration with Plus 55.

24, 25, 26 OCTOBER (Monday > Wednesday)

Meeting

LIBRARY DAY

This year we will take advantage of Library Day to organise activities around the GLAM. GLAMwiki is a project for libraries, museums, archives and galleries. What projects are underway? What projects are there in the Basque Autonomous Community to incorporate local content? All this and another surprise organised jointly by the San Sebastian Library Network (Donostia Kultura), Koldo Mitxelena library (DFG) and Ubik, Tabakalera's creation library.

5 > 12 NOVEMBER (Saturday > Saturday)

Meeting

KOMIKILABEA. COMIC BOOK WEEK

📍 Ubik

Comic books are a graphic and visual way of telling stories. They give us the opportunity to tell fictional and non-fictional stories through sequential drawings and illustrations. In addition to texts, images, colours, pace and layouts, they help us immerse ourselves in the stories, embracing feelings and experiences.

Taking non-fictional stories as a base, Ubik will offer presentations and workshops that will enable us to get closer to the world of social comics.

Komikilabea is a project in collaboration with Donostia/San Sebastián 2016 and the culture section of the Diputación Foral de Guipúzcoa. It also has the support of: Donostia Kultura (Semana de Terror and Red Municipal de Bibliotecas), Kutxa Kultur, Kunsthall Centro Superior de Diseño, Kaxilda and Tabakalera.

6 > 12 NOVEMBER (Sunday > Saturday)

Workshop

STORYLINE. MAKING A COMIC COLLECTIVE

Ibai Aizpurua, Luis Doviso, Mai Egurza, Paula Estevez, Joseba Larratxe, Aritz Trueba.

10:00 - 14:00 / 16:00 - 20:00 EU + ES

📍 Ubik

I have a challenge for you: create a comic between you all! Are you up for it? You can be the creator of a comic for a week.

In addition to watching skilled cartoonists work, we can all take part in the creation of a collective comic.

Gather your ideas together, sharpen your pencil and get involved!

9 NOVEMBER (Wednesday)

Presentation

CLEARER? IN COMICS! A SELECTION OF SOCIAL COMICS BY DAVID ZAPIRAIN

David Zapirain

18:00 - 19:30 EU

📍 Ubik

Conflicts, wars, social movements, struggles of the most deprived... Comics are also an essential window into current situations. David Zapirain has made a selection of social comics which will be on show at Ubik. What criteria did he base it on? What are the essential titles? Come to the presentation and discover these extraordinary titles. You can also take them out on loan.

10 NOVEMBER (Thursday)

Workshop

SUPERWOMEN. A FRESH LOOK AT THE USUAL POINT OF VIEW

Ainara Azpiazu, Axi

18:00-19:30 EU

📍 Ubik

Writers, readers, cartoonists, characters, protagonists... What is the place of women in comics? Taking the Bechdel Test as a starting point, we will analyse the treatment, presence and roles of women in the world of comics in this workshop.

27, 28, 29, 30 DECEMBER, 3, 4, 5 ENERO (Tuesday > Friday)

Workshop

WINTER WORKSHOPS

10:00 - 14:00 / 16:00 - 20:00 EU + ES

Registration required.

📍 Ubik, Workshop

Having free time, is there any better occasion to come to Ubik and take part in the workshops? We will enjoy ourselves around thinking, sounds and audiovisuals.

Aimed at the young and old, in the morning and in the afternoon/evening. More information soon on our agenda and the website.

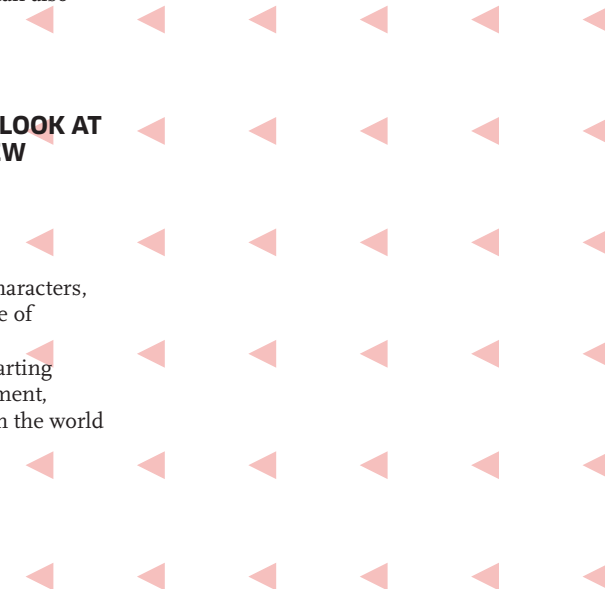

ARTIST'S SPACE

The aim of Artist's Space is to provide artists and cultural agents resources for the development of artistic projects. These resources include working studios, technical equipment, an international residency programme, as well as a programme for supporting practices and enhancing their visibility. It also provides general information and guidance on administrative issues, scholarships, and other residency programs.

14 > 18 NOVEMBER (Monday > Friday)

Seminare

**CURATORIAL PROGRAMME:
CURATOR OF RESEARCH**

Coordinated by Katerina Gregos

Guest: Johan Grimontprez's, Adelita Husni-bey

10:00 - 13:00 / 15:00 - 18:00 EN

Registration required.

Habrá proceso de selección.

Aimed at curators and professionals linked to artistic practices.

📍 Workshop

Looking into questions such as democracy, rights, the legacy of colonialism, historiography, suppressed narratives, and politically contested issues such as the limits of freedom of speech and the recent refugee crisis, the seminar will examine problems of representation and methodological strategies in relation to curating the political from a research-based perspective. It will also look into the different ways how research translates into artistic praxis and visuality.

3 DECEMBER (Saturday)

Presentation + conversation

ENDPLAY: AN OBSERVATORY

Lisa Nelson

19.00

📍 Different spaces of Tabakalera

After the laboratory set up in the production spaces at Tabakalera, the artist will be presenting *EndPlay: An Observatory*, a piece that will enable us to watch together the creation of a dance based on a single

action, the intoxication of the body by the imagination, the dance of consequences, a theatre of opinions, the ephemeral union of attentions and intentions that lights up the body's circumstances.

This project is a collaboration between Azala and Tabakalera.

> 5 NOVEMBER (Saturday)

Call

OPEN CALL FOR RESIDENCIES

The call will be open until the 5th of November, 2017. More information: www.tabakalera.eu

Tabakalera launches the third open call for the development of artistic residencies. The submission of proposals can be done from the 23rd of September, 2017. The residencies respond to the following modalities: curator's residency, development of an artistic project, local/non-local (a local artist or cultural agent invites a non-local artist or cultural agent for the development of an artistic project), audiovisual, artistic research (in collaboration with DSS2016) and production assistance.



EndPlay: An Observatory

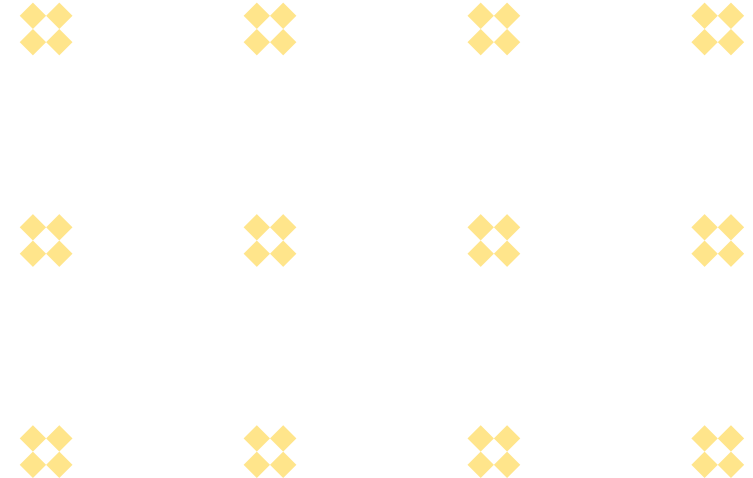

T

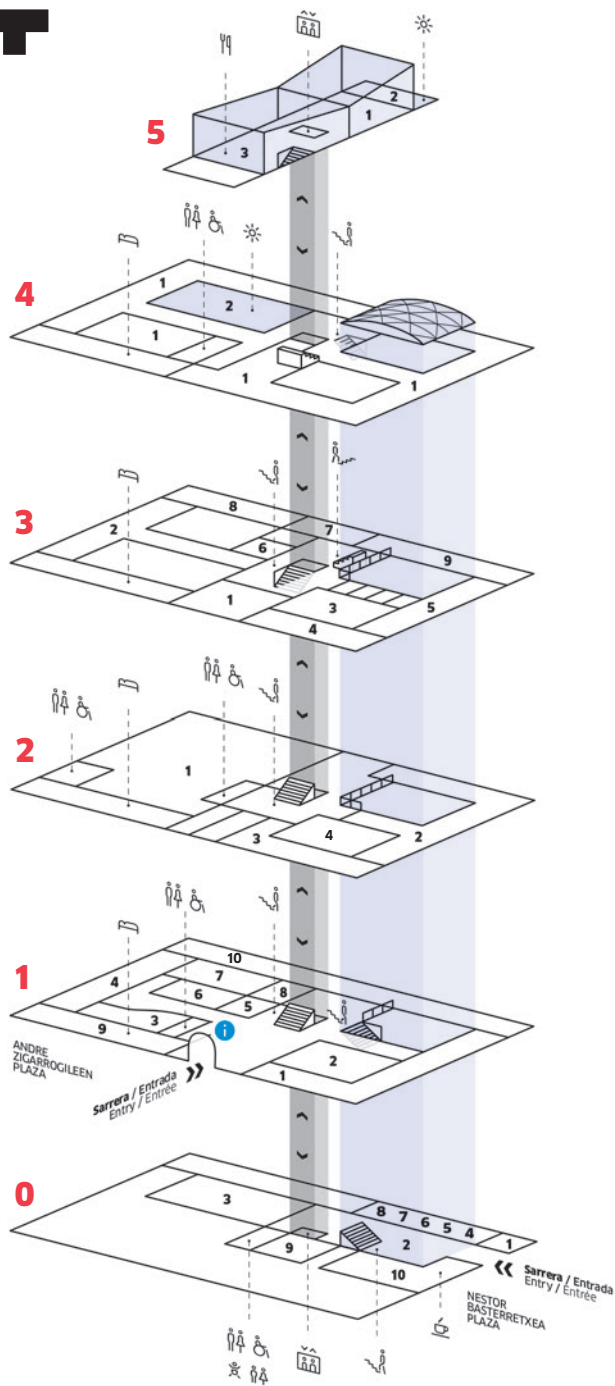

Information point



Lifts



WC



Changing Table



Stairs



KUPULA Restaurant



TABA



Hotel-Residence

+info
www.tabakalera.eu

FLOOR

0

- 1 STORAGE
- 2 SQUARE
- 3 KUTXA KULTUR ARTEGUEA
- 4 NANA
- 5 LÄNTOKI
- 6 ARTEUPARTE
- 7 NON GALLERY
- 8 EL SEKADERO
- 9 KABIAGUNEA
- 10 TABA

3

- 1 TABAKALERA'S OFFICE
- 2 HIRIKILABS
- 3 WORKSHOP
- 4 PRODUCTION
- 5 STUDIOS
- 6 K HALL
- 7 ZINEUSKADI
- 8 ETXEPARE BASQUE INSTITUTE
- 9 IMPACT HUB DONOSTIA

1

- 1 TABAKALERA'S EXHIBITION HALL
- 2 PATIO
- 3 CINEMA, SCREEN 1
- 4 Z HALL
- 5 EDUCATION ROOM
- 6 KUTXA KULTUR KLUBA
- 7 KUTXA KULTUR ARTEGUEA
- 8 MISCELANEA
- 9 HOTEL-RESIDENCE
Opening Soon
- 10 SPACE 1

4

- 1 KUTXA KULTURGUNEA
- 2 ATTIC

2

- 1 UBIK
Tabakalera's
Creation Library
- 2 SAN SEBASTIAN
INTERNATIONAL FESTIVAL
- 3 BASQUE FILM ARCHIVE
- 4 CINEMA, SCREEN 2

5

- 1 PRISMA
- 2 TERRACE
- 3 KUPULA
Restaurant

Tabakalera is a free access public space for enjoying contemporary culture.

TABAKALERA



**INTERNATIONAL
CENTRE FOR
CONTEMPORARY
CULTURE**



OPENING HOURS



CENTRE

Monday to Thursday:

08:00 - 22:00

Friday:

08:00 - 23:00

Saturday:

10:00 - 23:00

Sunday and holidays:

10:00 - 22:00

UBIK

Creation Library.

Tuesday to Saturday:

10:00 - 14:00

16:00 - 20:00

Sunday and holidays:

10:00 - 14:00

EXHIBITIONS

Tuesday to Thursday:

12:00 - 20:00

Friday:

12:00 - 21:00

Saturday:

10:00 - 21:00

Sunday and holidays:

10:00 - 20:00

+Info: info@tabakalera.eu · 943 11 88 55 · Andre zigarrogileak plaza 1,
20012 Donostia / San Sebastián · Gipuzkoa

tabakalera.eu



#gozatutabakalera



Gipuzkoako Foru Aldundia



Donostia Udala
Ayuntamiento de San Sebastián



DSS2016.EU