

12.The Burial of the Dead (2016)

Technical details

Three-channel HD video installation, 2:39, color, three-channels mono sound, 90 min. sync in a loop, Peru – Portugal – Switzerland – France

Synopsis

There is no need to design or stage an apocalyptic landscape, for the earth we inhabit is already in crisis and the apocalypse is now. Attempting to redefine ethnographic film tradition, *The Burial of the Dead* is a video installation set in the Peruvian town of La Rinconada, at an altitude of 5,500 meters on the edge of a gold mine; it captures a dystopian world that scarcely seems possible in the twenty-first century. The cinematic triptych conveys the extremity of its situation and the dimensions of its misery without having to resort to graphic images. Indeed, it is a Dante-esque Escher-escape of haunting beauty.

Credits

The Burial of the Dead is an original video installation by the artist Salomé Lamas produced in the framework of the Biennial of Moving Images 2016 (BIM), Switzerland.

The project is coproduced by Centre d'Art Contemporain de Genève with the support of Fonds d'art contemporain de la Ville de Genève – FMAC, Fonds d'art contemporain du Canton de Genève – FCAC, Faena Art, In Between Art Film and HEAD.

The project is produced with materials collected in April 2015 for the shooting of the feature film *Eldorado XXI* (2016) by Salomé Lamas, produced by O Som e a Furia and Shellac Sud with the support of Instituto do Cinema e Audiovisual – ICA, Centre national du cinéma et de l'image animée, Ministère des Affaires Étrangères et du Développement International – Institut Français – CNC, EURIMAGES—Council of Europe, and the additional support of FIDLab2013 FID Marseille, Rockefeller Foundation Bellagio Center, Berliner Kuenstlerprogramm des DAAD, The MacDowell Colony, Bogliasco Foundation, and Yaddo.

Shooting of *Eldorado XXI* (2016), April 2015

(Credits for other production stages of *Eldorado XXI* excluded)

Written and directed: Salomé Lamas

Producers: Luís Urbano and Sandro Aguilar

Coproducer: Thomas Ordonneau

Associate producer: Maxim Holland

Cinematography: Luis Armando Arteaga

Sound: Bruno Moreira

Production director: Raquel da Silva

Production manager: Lali Madueno

Fixer: Niche Neceforo, Leon Quispe Huaranca

Drivers: Edwin & Nercy

Catering: Juan Quispe
Sound and image equipment: Screen Miguel Nabinho
Insurance: Gras Savoye, Riskmedia

Portugal, O Som e a Fúria
Production: Joaquim Carvalho, Cristina Almeida, Fabienne Martinot, Sofia Bénard
Accountants: Aline Alves, Amadeu Dores

France, Shellac Sud
Coordination of production: Francine Cadet
Assistant: Marion Schreiber
Administration of production: Cyrille de Laleu
Assistant: Elodie Latriglia

Peru, Tambo Films
Coordination of production: Celine Wald
Accountant: César Egoavil

Additional credits for *The Burial of the Dead* (2016)
Editing: Salomé Lamas
Editing assistant: Rita Quelhas
Intern: Henrique Real
Sound concept and design: Miguel Martins
Sound mix: Miguel Martins
Sound studio: Sunflag
Color correction: Caique De Souza
Lab: Filmfactory
Original music: João Lobo and Norberto Lobo
Exhibition design: Fernando Brízio
Translations: Gloria Dominguez

Switzerland, Centre d'Art Contemporain de Genève
Head of exhibitions and registrar: Maxime Lassagne
Head of communication and special projects: Natalie Esteve
Assistant to the director and external relations: Priscilla Gonzalez
Administration: Régine Gorgerat
Technical coordination: Benoît Delaunay
Education department: Frédéric Stordeur

Biennial of Moving Images (BIM)
Artistic direction, curators: Cecilia Alemani, Caroline Bourgeois, Elvira Dyangani Ose, Andrea Belini

Video installation guidelines

TECHNICAL DETAILS

Three-channel video installation, HD, 2:39 color, three-channels mono sound, 90 min. sync in a loop, Peru – Portugal – Switzerland – France

a) Materials

Three-channel video installation, HD, 2:39 color, three-channels mono sound
 MASTER LEFT CHANNEL 1 HD Mov. / Apple Pro Res 4444 / color / 2:39 / Sound Mono

MASTER CENTER CHANNEL 1 HD Mov. / Apple Pro Res 4444 / color / 2:39 / Sound Mono

MASTER RIGHT CHANNEL 1 HD Mov. / Apple Pro Res 4444 / color / 2:39 / Sound Mono

b) Material for base or background (*linen, aluminum plate, type of paper, pedestal, etc.*)

Check installation build up plans.

When possible respect the instructions and exhibition design:

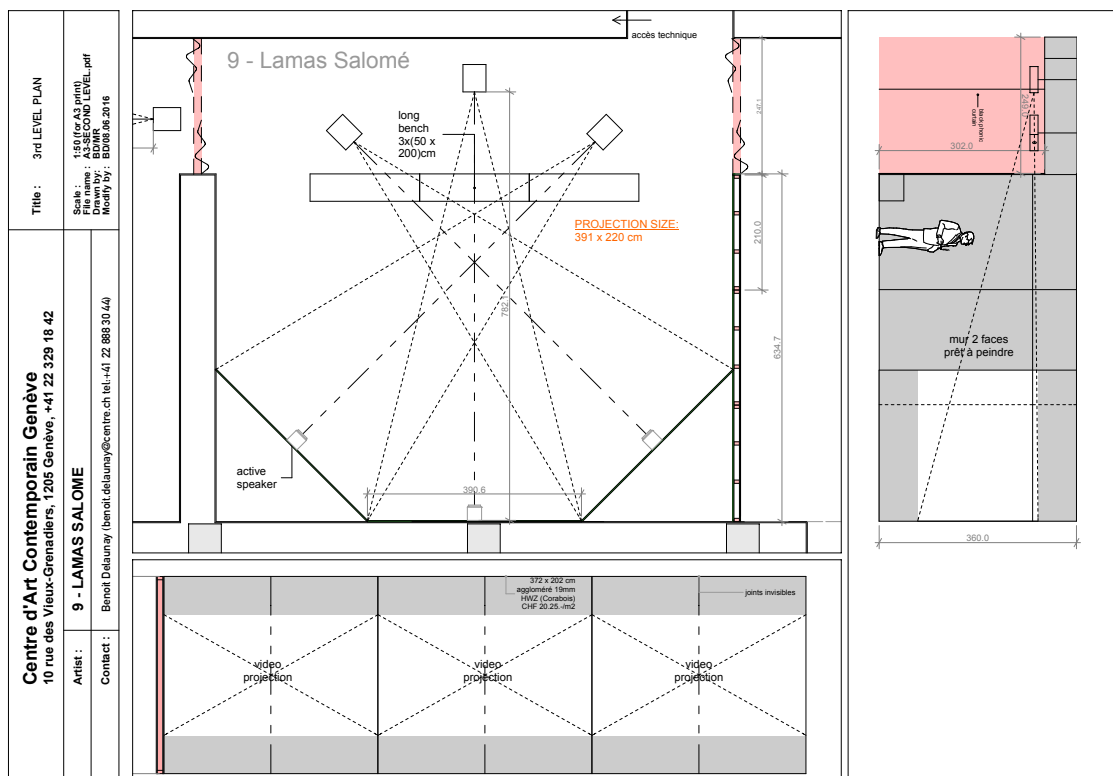

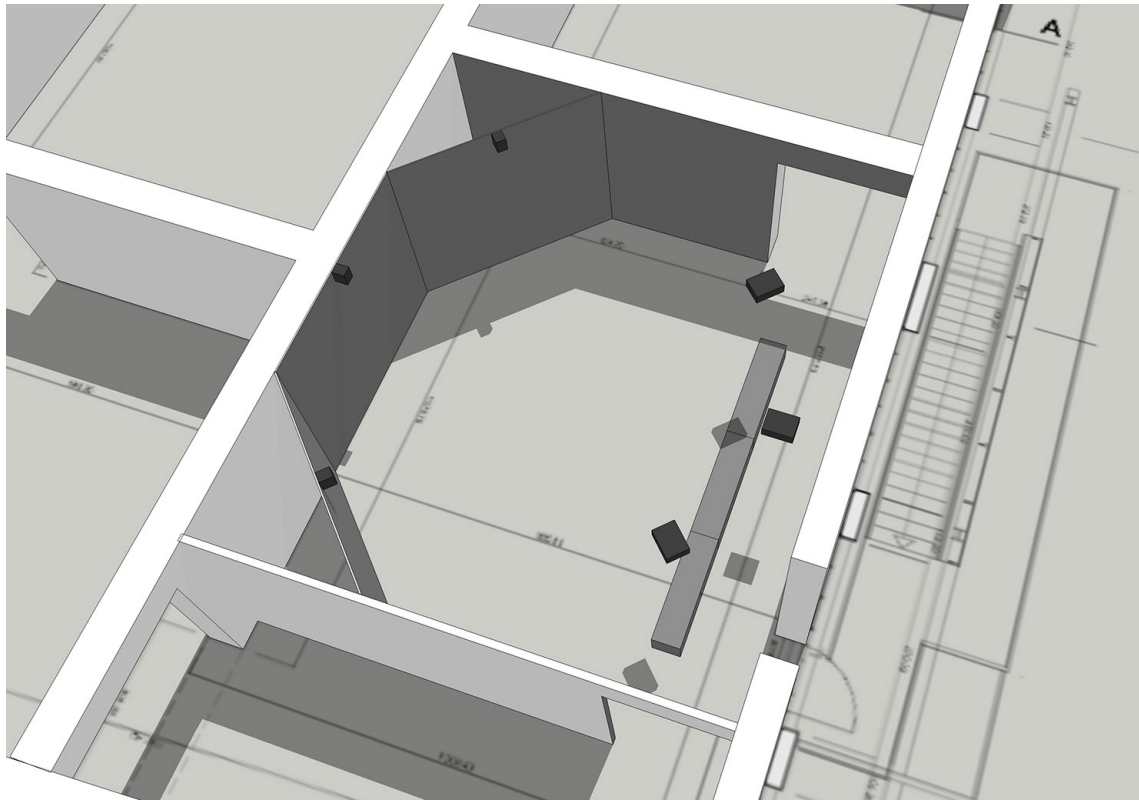

A. Walls and Bench Painted
Color Ref: NCS S-5500-N

a) Bench option I

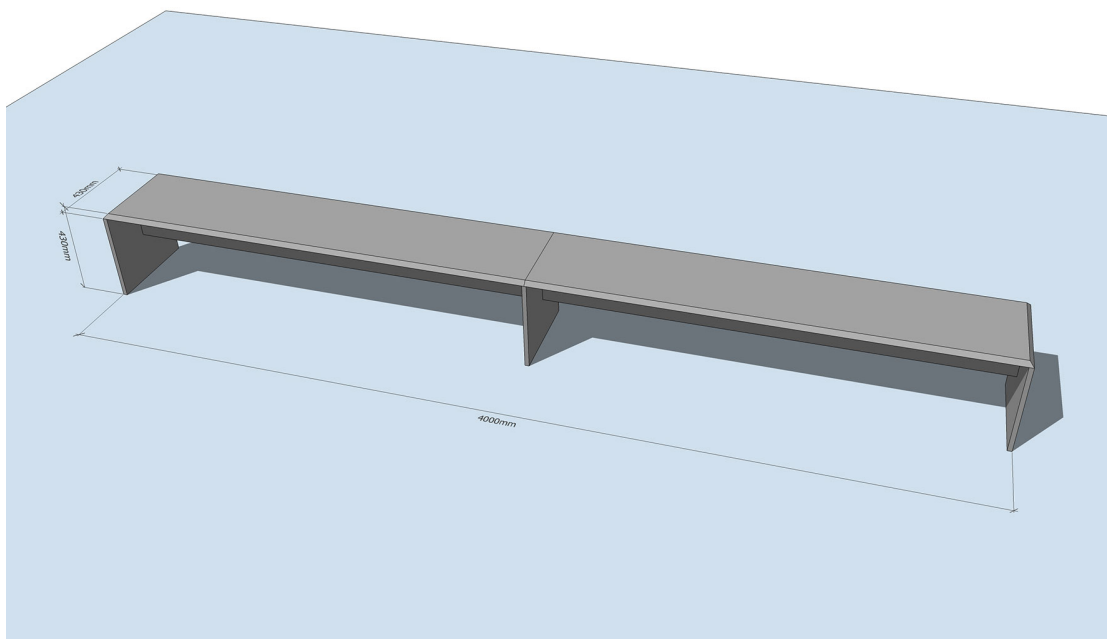

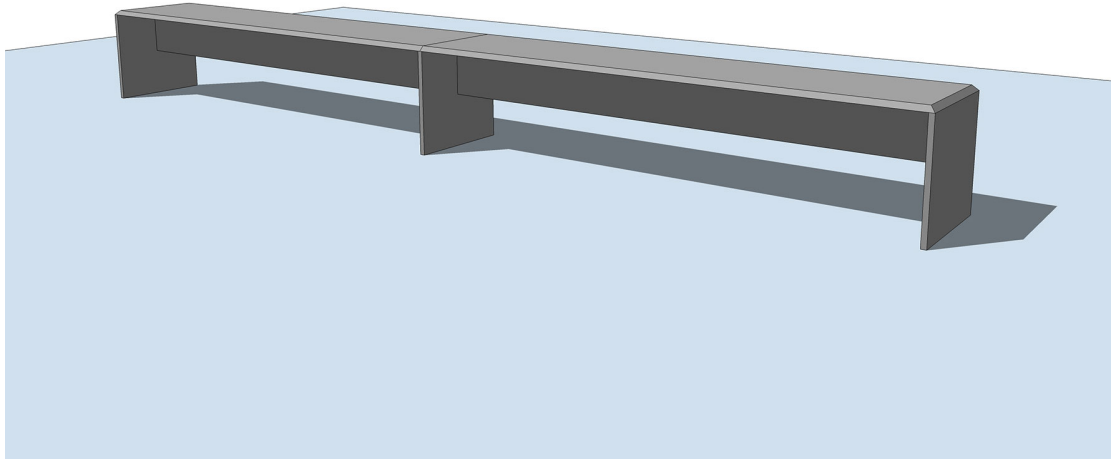

b) Bench option II

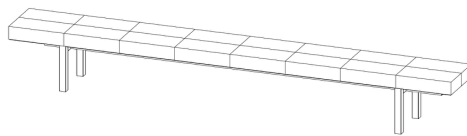

Argila natural para moldar da Sio - 2
16 unidades de 12,5 Branco/White
fornecedor: <https://www.pontodasartes.com>

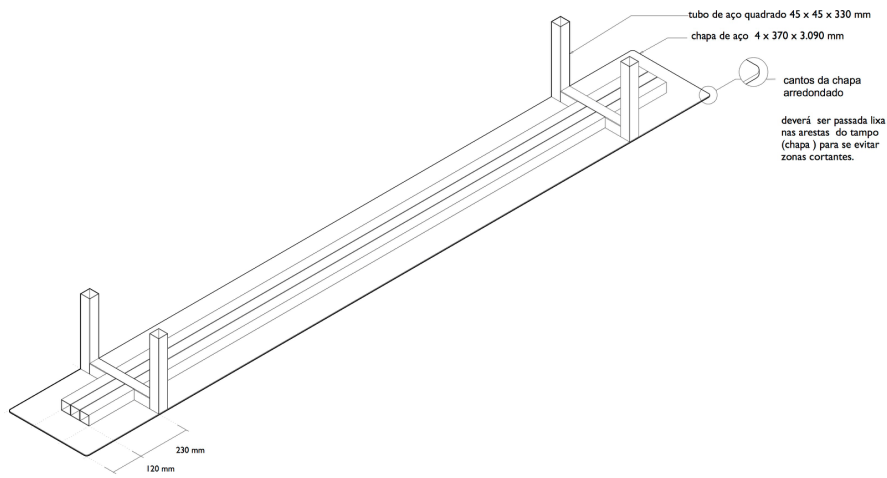

Estrutura do banco para The Burial of the Dead de Salomé Lamas

Technical drawings by Fernando Brizio of bench, designed for The Burial of the Dead (2016)



c) Floor



Stone image reference

B. Sound specs

3 – speakers;

C. Image specs and dimensions

a) 3 – projectors (Equal Model-Ref. / Lamps 0h / New if possible – for color matching between screens)

Minimum projection area 391x220 cm

b) 1 – Media Player for perfect sync
(Bright Sign <https://www.brightsign.biz> for perfect sync between the 3 channels, Matrox, or other system)

If using Bright Sign player / recommended encoding of MASTER files

.MP4 files

Codec H264

Max. bit rate 25-30 Mbps

FAQ / Support:

<http://support.brightsign.biz/hc/en-us/articles/218065707-Which-quicktime-mov-mp4-file-types-do-BrightSign-players-support->

D. Text accompanying the work should be printed and made available to the public. Included in the materials delivered - at the end of the doc.

c) treatment(s)/product(s) in case of restoration (*p.ex : silicone for latex*).
Please indicate the name and address of (the) firm to contact.

For preservation materials should be copied and updated to newer formats in order not to become technologically outdated. There should be a back up of the MASTERS.

Film Factory <http://filmfactory.fr/> or similar service provider.

PREPARATORY WORK(S)

2016 - Eldorado XXI

HD video, 2:39 color, Dolby 5.1 sound, 125 min., Portugal-France-Peru

Production: O Som e a Fúria, Shellac Sud, Tambo Films

Support: Instituto do Cinema e Audiovisual (ICA), Centre National du Cinéma (CNC), EURIMAGES – Council of Europe

Development awards: FIDLab 2013 FID Marseille (Le prix Sublimage, Le prix Vidéo de Poche).

Development Support: DocStation 2014 Berlinale, Rockefeller Foundation

Bellagio Center, Yaddo, Bogliasco Foundation, Berliner Künstlerprogramm des DAAD, Critical Media Practice – Workshop (WIP), Harvard University

Distribution: O Som e a Fúria, Shellac Sud



Salomé Lamas, *The Burial of the Dead*, 2016. Installation view, Biennale de l'Image en Mouvement, Centre d'Art Contemporain Genève, 2016

SALOMÉ LAMAS

b. 1987, Lisbon, PT. Lives and works in Lisbon, PT
 In a fertile occupation of no man's land, Lamas attempts to dissolve the apparent border between documentary and fiction, with an interest in the intrinsic relationship between storytelling, memory, and history, while using the moving image to explore the traumatically repressed, seemingly unrepresentable, or historically invisible, from the horrors of colonial violence to the landscapes of global capital.

THE BURIAL OF THE DEAD, 2016

There is no need to design or stage an apocalyptic landscape, for the earth we inhabit is already in crisis and the apocalypse is now. Attempting to redefine ethnographic film tradition *The Burial of the Dead*—Lamas' project for the Biennale de l'Image en Mouvement—is a video installation set in the Peruvian town of La Rinconada at an altitude of 5,200 meters on the edge of a gold mine. It captures a dystopian world that scarcely seems possible in the 21st century. Lamas has constructed a cinematic triptych to convey the extremity of this situation and the dimensions of its misery without having to resort to graphic images—indeed a *dantesque* *escheresque* of haunting beauty.

Biennale de l'Image en Mouvement

Salomé Lamas In conversation with João Ribas

JÓÃO RIBAS

There is in your work a strong interest in narrative that seems to go beyond any strict definition of fiction or documentary, or distinctions of genre, such that your films exist at a limit where one work begins to take over or supersede another.

SALOMÉ LAMAS

For me nonfiction is a sort of a rabbit hole. Another thing I'm very much attached to is the notion of *parafiction*. Today we welcome make-believe and plausibility against authenticity. The limits of documentary filmmaking involve this idea that the documentary is constructed upon reality. If we build a brick wall upon the real, with its foundations on reality, and then remove one or two fictional bricks of this wall, the wall will crumble, so we do need these fictional bricks to believe in what is placed in the scene. Therefore we end up reflecting on how we might erase the borders of vectors such as storytelling, memory, and history. How can we *trouillir*, or play with, the border between fact and fiction? How can we reveal these mechanisms? There is no clear judgment or statement being drawn on reality; there is an assemblage of proposals to be considered by an audience.

JR

There is also a tension in films like *Eldorado XXI* between what we associate with the documentarist image and the narrative power of social reality, where storytelling and witnessing are intertwined.

SL

One should think twice about imprinting a new image because of the overall saturation of visual stimulus in contemporary society. When we create images, we are somehow translating the language of things into a graphical language. I personally like to reflect upon what is at stake in that process: what distinguishes an image from its phenomenological essence is its historical mark. Each present is determined by its synchronous images; each "now" is a "now" of categorical reference. One in which truth is filled with time until its explosion. This explosion is the *intentional* death, which coincides with the truth born of historical time. The image is the suspended dialectic between past and present, containing on a higher level the mark of the critical moment (to borrow from Walter Benjamin).

JR

The ethics of representation.

SL

I suppose that is the only possible way for me to bear the fact that I make nonfiction films, and to accept that making nonfiction is a dirty job. Although there are ways to seek some kind of balance. And that is also why sometimes my presence in one work is more noticeable than in others. Every filmmaker who works with nonfiction film has to deal with core ethical questions. You cannot be separated from the way you inhabit the world. In general, the way you shape your relationships and your moral behavior.

Nonfiction filmmakers are responsible for what they represent, exposing personal affairs for public discussion. They are responsible for their subjects, and for their audiences. There are always judgments involved.

Filmmakers need to weigh their actions, and they should regard production, representation, and reception as social acts with ethical consequences. More than simply asking if what we see and hear is credible or "authentic," we should think about what interests a documentary serves, what impact it might have on its spectators, and whether or not it takes into account the welfare of the people represented.

Let's think of the following vectors, and how they are related to the filmmaker, sponsors, subjects, and spectators. What is the power/wage contained in each of these links? Are honesty and fidelity equal to responsibility? No. There are different ways of pursuing equilibrium, but seeking a balanced methodology will only allow the gap to be clearer. This gap has a place, and it is precisely on nobody's land that the film

can exist as an autonomous piece. If on one hand we might be tempted to examine documentary as an exercise of political and social power, on the other hand it does not mean that the filmmaker is the wall—and this is precisely where things become interesting. If we regard power relations as potentially productive. As a filmmaker one should be aware that a film allows the spectator to know as much about the represented object as about the maker. Therefore it is pertinent that the maker finds an authorial and ethical voice.

JR
So the films are in some sense portraits. The structure of a lot of your work stems, I think, from how personal biography or experience intersects with larger historical, political, or economic narratives, telescoping out from the individual experience of one person and how that life is a vector for a larger context. Take for example the protagonist of *No Man's Land* (2012).

SL
What is entitled to be preserved? How can ordinary people or researchers access this patrimony? Who owns it? Why are some sections confidential? Who determines confidentiality? How high are the preservation and storage costs? What is lost when the Library of Alexandria burns down? It is humanity's duty to collect, and to remember, but collections are limited, and someone is curating. We cannot separate history from trauma, and the question raised could be how one can represent the trauma. Something that is both unforgettable and unmemorable—can't it be a process of desire? There are incredibly beautiful archive projects around the world. As a kid, and still today, whenever I visit a foreign country I look for the national archive. Accessibility differs enormously from country to country. Yet we—if there is still a "we" to protect—cannot forget. *No Man's Land* focuses on the testimony of Paulo de Figueiredo as he narrates his involvement as a hired killer for special military forces during the Portuguese colonial war, the part he played in the GAL (Antiterrorist Liberation Group), a death squad illegally established by the Spanish government to annihilate high officials of the ETA, and his work as a mercenary for the CIA in El Salvador. Rather than being interested in affirming the veracity of the historical record or in proving an official narrative, *No Man's Land* dwells in the present moment of witnessing, the space inhabited by the performance of a memory. I tried to create a set or a stage where information or document are peripheral to the question of how one plays out and affirms as history one's own personal truth.

JR
The films also revolve around a set of relations, in that they create a space for a narrative to emerge.

SL
My work dwells on a couple of mainlines. One of these could be understood as a flexible account of the notion of limit—border—margin. I flirt with "crystal-image" and "crystal-image" are unpredictable. Images contain riddles, they are traps, and many times we must wonder if we are not just casting an illusion. I like to lay the cards out in front of the viewer, to play a fair game, but I'm also forcing the viewer to be active in their reading. One has to cherry-pick the way one wants to perceive what is being presented on-screen, and struggle with one's own preconceptions, ethics, judgments, and so on. It is never about the edges, the black and white. It is about the gray areas. Lazy people are a drag. "To wait" is also a constant in my practice. That is a key question: How long do I have to wait until reality becomes extraordinary? Sometimes it comes to: How much time can the production last? I'm not mystical, but I have strong convictions that filmmaking, besides being the work of a shoemaker, is also an act of faith and that each image is able to communicate its duration in juxtaposition with what comes before and after. I also believe in honesty, and if your aim is to challenge or even to trick the viewer you should be explicit about what you are doing (even if you just reveal it in the end).

JR
This has an interesting relation to cinematic time. There is for example the long take in *Eldorado XXI*.

Bernardo de l'Imatge en Moviment

Júlio Ribas

Salmé Lamas

Bernardo de l'Imatge en Moviment

Júlio Ribas

Salmé Lamas

SL
That brings us to how duration affects our perception of the images, how the viewer perceives repetition within the extended image, and how that is linked with the notion of becoming. How duration within a particular image is also unveiling the creative process, the waiting methodology, the falling, unveiling freedom and fidelity—concepts that would never go together except in the act of translating reality. In *Eldorado XXI* there is a take that is close to one hour (I let the camera roll for two hours, in fact) while dozens and then hundreds of miners, growing under the weight of their burdens, trudge by in squeezed files, some heading up and others down the narrow, steep mountain path, the scene starting out in this twilight and persisting into pitch black (by the end all we see are the crisscrossing beams of the workers' hard hat headlamps), the soundtrack consisting of the crunch of their boots played off against stray wisps of audio testimony and wailing passages of radio banter. Lawrence Weschler described it as "a human ant file, a Danteque Escheresque, Midian Sisyphic." I like to think of it as a take trompe l'œil.

JR
Tell me about your interest in particular places and landscapes: Transnistria, a Peruvian Mine, a holiday camping site, and so on?

SL
I do not have an easy relationship with borders. They frighten and unsettle me. I have been searched, provoked, delayed time and time again for having had the senselessness to cross a few meters of land. Borders are bureaucratic lines, authoritative and enemy. Their existence is routinely criticized by academic geographers, who portray them as hostile acts of exclusion. Nonetheless, in a world without borders, where would we escape to? Where would it be worth going to?

I usually address realities that present some kind of discomfort, nowhereless places, or territories hard to describe in one blow. "No man's land" is the natural land of the imagination. It is in that non-place that we are ourselves to withstand the immaculate silence of the universe that goes beyond our own imaginations, so that we do not succumb to pure panic and to the threat of dissolution. Silence from the above that is foreign to us, but to which we also belong. This part of us is abandoned to pure possibilities, unadulterated observations of any form, the inertia of fear, from which we tirelessly protect ourselves by convention. Besides the seriousness and the honesty of the work, there is also something that you might be tempted to mask with idealistic and noble intentions, but that deep down also serves your self-obsessed needs for challenging experiences. Some of these interactions are tough, but when you look back at them, you realize that you have grown more capable of enduring the next challenge. It is a way of visiting this strange place we all call reality. Of course there are work commitments, expectations, partners, and other responsibilities, but no matter the outcome of the project, I am there first and foremost for the ride. I guess I can no longer distinguish life from what I do. I am happy I'm not working on Wall Street because I would have a shorter life. Let's just say that creation arises from a fact that is intolerable to suppose: that what is the most precious in the world should be given a chance. *Eldorado XXI* and *The Burial of the Dead* (2016), the latter the first one-chained drift commissioned by Centre d'Art Contemporain Genève, are indeed great examples. At 5,100 meters (16,700 feet), the sprawling Andean gold mining encampment of La Rinconada, in the southeastern corner of Peru, is the highest-elevation permanent human settlement in the world, with a population of close to thirty thousand souls, the vast majority of them desperately unfortunate. Nearly all the mines and miners there are "informal," a term that critics consider a euphemism for "illegal." Most don't receive salaries, but do receive benefits, but work on an ancient labor system called *cachorro*. This system is usually described as thirty days of unpaid work followed by a single frantic day in which workers get to keep whatever gold they can haul out for themselves. It all started in 2013, before the premiere of *No Man's Land* in Berlin.



one word, "La Rinconada," one thought, that I want to make it up there; one realization, that I know there are no guarantees, given the altitude challenge and the outline character of the site. But let's try to find the resources, let's give it a try, and I'll bring back a film—easy. Anyhow, it has come to my attention that National Geographic wants to do something up there. They want to look for the social drama. Not even once did it cross my mind to create a social drama.

JR

You process is very intimate in a way, working with a small crew and being present within the literal and thematic landscape you are trying to depict.

SL

One must be very assertive, and convince people to go along with you. Some projects start with a bluff. I guess that by now, the people I work with are expecting the bluff. I am a bad poker player: You have noticed that already in my films. I am very grateful that on a number of occasions, some facing more risks and unpredictability than others, the crew not only "jazz to jazz," but also tried the bet. Let's see how long I can keep up with the trick! I think that in most cases it is clear from the beginning that things can "go wrong," and we accept those conditions as part of the project.

We also always have multiple backup plans. For me that is what it means to work with a good producer. It would not have been so unexpected if suddenly, while shooting Eldorado XXI, I had to call up the production company—O Som e a Fúria in Lisbon—to say that we must send the crew home. Honestly, this phone call was about to happen shortly after the second week of shooting, but we kept going, and I found another way, thanks to the crew.

The projects have different scales and commitments, crew and budget wise. There are smaller-scale projects that I self-produce or coproduce. So let's say that, in the end, I am extremely pragmatic, and try to predict all possible scenarios and possible consequences. You have to be honest, lucky, play an open game, and find the right partners.

JR

You've worked in both the gallery context and more cinematic contexts. Are there qualities particular to either that interest you?

SL

I would say that each project encounters its own space, and that some of my work has the flexibility of fitting both, but even if we were screening the exact same work in both scenarios, the perception of the viewer would change. The social codes regarding how to circulate, occupy, and behave in the space of the white cube versus the black box are different. Their traditions, histories, and cultural impacts are different. Notions of expanded cinema or video installations in gallery spaces lead to different experiences, which lead to different outcomes, which lead to different ways of reaching an audience.

Also, while single-channel works may travel easily from space to space, a multi-channel video installation usually is site-specific, with a carefully planned display for that particular space. In both the gallery and the theater space, the intentions are identical. The tools and means to address reality are the "same," and only the formats and exhibition displays are different. I usually invite a designer to outline the gallery space, and together we try to direct and predict the spectators' movements. It is fun, and I tend not to compromise, budget wise, on how the installation should be set up; I would rather design a project that suits the available budget or conditions.

Title	The Burial of the Dead
Year	2016
Technique	Three-channel video installation, 2.35, sound mono three-channel
Duration	00:00:00
Courtesy	the artist

Bernadé de l'Imatge en Movimento

João Ribas

Salomé Lamas



Salomé Lamas En conversation avec João Ribas

JÓÃO RIBAS

Il y a dans votre travail un intérêt certain pour le récit, qui semble dépasser le cadre strict de la fiction ou du documentaire. Vos films existent à la croisée de plusieurs genres.

SALOMÉ LAMAS

Pour moi, la para-fiction, c'est un peu comme le puits où tombe Alice. Il y a une autre notion à laquelle je suis très attachée, c'est celle de para-fiction. Aujourd'hui, on a tendance à privilégier le faux-semblant, ou ce qui est simplement plausible, au détriment de l'authenticité. La limite du cinéma documentaire, c'est l'idée même que le documentaire est construit sur la réalité. Si on construit un mur de briques sur le réel, un mur dont les fondations reposent sur la réalité, et qu'on entasse une ou deux briques fictionnelles à ce mur, il va s'écrouler : on a besoin de ces bouts de fiction pour croire à ce qui est placé dans le champ. Ce qui nous pousse à réfléchir à comment gommer la frontière du récit, du souvenir, et de l'histoire. Comment se débarrasser de la frontière entre réalité et fiction, ou jouer avec elle ? Comment révéler ses mécanismes ? On ne porte pas de jugement, on ne fait pas de commentaire sur la réalité : il y a seulement un montage de propositions offert à l'appréciation du public.

JR

Dans des films comme Eldorado XXI (2016), il y a aussi une tension entre ce que l'on associe à l'image documentaire et la puissance narrative de la réalité sociale, où récit et témoignage sont intimement liés.

SL

Dans notre société contemporaine qui est saturée de stimuli visuels, on devrait toujours réfléchir à deux fois avant de créer une nouvelle image. La façon de créer des images, on traduit en quelque sorte le langage des choses en langage graphique. Personnellement, j'aime bien interroger ce qui est à l'œuvre dans ce processus : ce qui distingue une image de son essence phénoménologique, c'est son marquage historique. Chaque présent est déterminé par ses images synchrones. Chaque « maintenant » est un « maintenant » de référence catégorique, dans lequel la vérité est remplie de temps, jusqu'à son explosion. Cette explosion est la mort de l'intensité, qui coïncide avec la vérité née du temps historique. L'image est la dialectique suspendue entre passé et présent, et contient à un niveau supérieur la marque du moment critique (pour emprunter à Walter Benjamin).

JR

Léthique de la représentation.

SL

J'imagine que pour moi, c'est le seul moyen possible d'assumer le fait que je fais de la non-fiction, et d'accepter que c'est un sale boulot. Même s'il est possible d'y trouver une sorte d'équilibre. Et c'est pour cela que ma présence est plus manifeste dans certaines œuvres.

Tous les réalisateurs qui font de la non-fiction sont confrontés à d'importantes questions éthiques. Nous sommes obligés de tenir compte de la façon dont nous habitons le monde en général, dont nous façonnons nos relations aux autres et notre posture morale.

Les réalisateurs de non-fiction sont responsables de ce qu'ils représentent, parce qu'ils soumettent des affaires personnelles au débat public. Ils sont responsables de leurs sujets, et de leur public. Le jugement n'est jamais loin. Ces réalisateurs doivent bien soupeser leurs actes, et ils devraient considérer la production, la diffusion et la réception de leurs films comme autant d'actes sociaux aux implications morales. Au lieu de simplement se demander si ce que l'on voit, ce que l'on entend, est crédible ou « authentique », on devrait plutôt réfléchir à quels intérêts sert un documentaire, quel impact il aura sur ses spectateurs, ou encore s'il prend en considération le bien des personnes qu'il donne à voir.

Réfléchissons à ces éléments : financeurs, sujets et spectateurs, pour

SALOMÉ LAMAS

1987, Lisbonne, PT. Vit et travaille à Lisbonne, PT

Occupant un terrain no man's land, Lamas cherche, par son travail, à aménager les frontières apparentes entre documentaire et fiction, avec un intérêt pour la relation intrinsèque entre narration, mémoire et histoire, tout en utilisant l'image en mouvement pour explorer le traumatisme refoulé, apparemment irréprésentable, ou historiquement invisible, des horreurs de la violence coloniale aux paysages du capitalisme mondial.

THE BURIAL OF THE DEAD, 2016

Il est inutile de concevoir ou de mettre en scène un paysage apocalypotique, la terre que nous habitons est déjà en crise et l'apocalypse c'est maintenant. Tentant de redéfinir la tradition du film ethnographique, Lamas propose dans The Burial of the Dead une installation vidéo tournée aux abords d'une mine d'or à une altitude de 5 200 mètres dans la ville péruvienne de La Rinconada. Ce film dépeint un monde dystopique qui ne semble guère possible au 21^{ème} siècle. L'installation en triptyque cinématographique souligne le caractère extrême de cette situation et l'impact de sa mise en scène avec à converger des images graphiques – créant ainsi un paysage dantesque d'une beauté envoiçante et rappelant les œuvres d'Escher.

Bernadé de l'Imatge en Movimento

238 239

Bernadé de l'Imatge en Movimento

João Ribas

Salomé Lamas

voir comment ils sont liés au réalisateur. Quel courant circule dans ces liens, et à quel voltage ? L'humanité et la loyauté sont-elles à mettre sur le même plan que la responsabilité ? Non. Il existe différentes façons de trouver un équilibre, mais le but de chercher une méthode équilibrée permettra de mettre en évidence le fossé. Car ce fossé a aussi sa place, et le film ne peut absolument pas occulter indépendamment de ces éléments. Si on peut être tenté d'envisager le documentaire comme un exercice de pouvoir politique et social, cela ne signifie pas pour autant que le réalisateur est dans le rôle du médiateur loyau – et c'est là, précisément, que les choses deviennent intéressantes, si l'on considère les relations de pouvoir comme potentiellement productives. Quand on est réalisateur, on devrait avoir conscience qu'un film permet au spectateur d'en savoir autant sur l'objet représenté que sur celui qui a fait le film. Par conséquent, il est pertinent que le réalisateur trouve une voie morale qui fasse autorité.

JR
Les films sont donc, en un sens, des portraits. Je crois que la structure d'une grande partie de vos travaux naît de la façon dont l'histoire biographique, l'expérience, croise le récit plus large de l'histoire, de la politique ou de l'économie. Elle jaillit de ce télescopage entre l'expérience individuelle d'une personne et ce contexte plus large dont cette vie est le vecteur. Prenons, par exemple, le protagoniste de *No Man's Land* (2002).

SL
Qu'est-ce qui mérite d'être conservé ? Comment les gens ordinaires ou les chercheurs accèdent à ce patrimoine ? A qui appartient-il ? Pourquoi certaines portions de ce patrimoine sont-elles classées confidentielles ? Qui décide de ce qui doit être confidentiel ? Comment coexistent la conservation et le stockage ? Qu'est-ce qui disparaît quand la bibliothèque d'Alexandrie brûle ? Il est du devoir de l'humanité de collecter et de sauvegarder, mais les collections sont forcément limitées, et confiées à quelqu'un ou une institution en particulier. On ne peut pas séparer l'histoire de la notion de traumatisme. Cela pose la question de la représentation du traumatisme. Quelque chose qui est à la fois inoubliable et immémorable : n'y a-t-il pas là un processus de décalage ? Il existe à travers le monde des projets d'archives incroyablement beaux. Depuis que je suis toute petite, chaque fois que je vais dans un pays étranger, je cherche les archives nationales. L'accessibilité diffère considérablement d'un pays à l'autre. Mais nous – il y a encore un « nous » à protéger – ne pouvons pas oublier. *No Man's Land* est le témoignage de Paulo de Figueiredo, qui raconte son engagement en tant que mercenaire des forces militaires spéciales pendant les guerres coloniales portugaises, le rôle qu'il a joué au sein des GAL (Groupes antiterroristes de libération), commandos paramilitaires créés dans l'illégalité par le gouvernement espagnol pour éliminer les responsables de l'ETA, ainsi que son rôle en tant que mercenaire pour le compte de la CIA au Salvador. Au lieu de s'interroger sur la véracité de la mémoire historique ou d'essayer de confirmer un récit officiel, *No Man's Land* se penche sur le moment du témoignage, sur l'espace habité par la mise en œuvre d'un souvenir. J'ai essayé de recréer un décor ou une scène où l'information ou le document sont géographiques et où l'essentiel est la façon dont quelqu'un joue et affirme en tant qu'histoire sa propre vérité personnelle.

JR
Vos films tournent aussi autour d'une série de relations, en ce sens qu'ils créent un espace où un récit peut émerger.

SL
Mon travail explore plusieurs directions. L'une d'elles est la notion de limite – frontière – marge, dans une acception large. Je flirte avec ce que j'appelle des « cytos-marges », et ces images sont impressionnantes. Elles contiennent des énigmes, tendent des pièges, et très souvent, nous devons nous demander si nous ne projetons pas une illusion. J'aime jouer cartes sur table avec le spectateur, franc-jus, mais je le force aussi à une lecture active. On doit choisir comment on veut percevoir ce qui est présenté à l'écran, et ce battrait avec ses propres a priori, sa morale, ses jugements, etc. Ce n'est pas une question de

Bernadé de l'Imagi en Mouvement

Júlio Ribas

Salomé Lamas

JR
C'est intéressant, par rapport au temps du cinéma. Par exemple, cette longue prise, dans *Eldorado XXI*...

SL
Cela nous amène à la question de comment la durée affecte notre perception des images.

Comment le spectateur perçoit la répétition à l'intérieur de l'image longue, et comment cela est lié à la notion de devenir. Comment la durée à l'intérieur d'une image révèle aussi le processus créatif, la méthode de l'attente, comment elle révèle la liberté et la loyauté – autant de concepts qui vont rarement de pair, hors des actes de traduire la réalité. Dans *Eldorado XXI*, il y a une prise qui dure près d'une heure (en fait, j'ai laissé la caméra tourner pendant deux heures). Lawrence Weschler la décrit ainsi : « Des dizaines, puis des centaines de mineurs, grugant sous le poids de leur fardeau, avancent péniblement en rangs serrés,

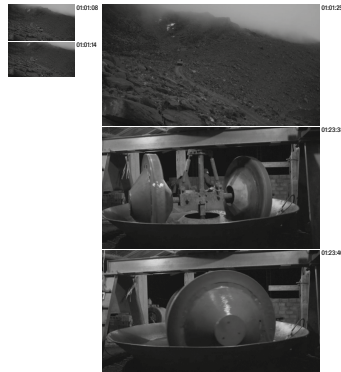

240 241

Bernadé de l'Imagi en Mouvement

Júlio Ribas

Salomé Lamas



certaines montants, d'autres descendant le long d'un étroit sentier de montage escarpé. La scène commence au crépuscule et dure jusqu'à la nuit noire. À la fin, on ne voit plus que le balais des faisceaux lumineux des lampes frontales des mineurs sur leurs casques. La bande son est faite du crissement de leurs bottes où se superposent ici et là des bouts de témoignages audio et des extraits flûtants de cassette radiophoniques. Une procession de fourmis humaines, de Sisyphes à la Mobilus, un Escapescapace denté... Moi, j'y vois volontiers un faux trouper-faut.

JR
Parlez-moi de votre intérêt pour les faux et les espaces parasites : la Transistria, une mine au Pérou, un terrain de camping, etc.

SL
Je ne suis pas très à l'aise avec les frontières. Elles me déconcertent et me font peur. J'ai souvent été faillié, retardé, agacé, pour avoir fait la bêtise de vouloir traverser quelques mètres de territoire. Les frontières sont des lignes administratives, autoritaires et hostiles. Leur existence est régulièrement critiquée par les géographes, qui les décrivent comme des actes d'exclusion. Toutefois, dans un monde sans frontières, vers où pourrions-nous aller ? Ou est-ce que cela vaudrait la peine d'aller ?

En général, l'interrogation des réalités qui génèrent une sorte d'incertitude, des non-dire, ou encore des territoires qui sont difficiles à décrire. Le no man's land, c'est le terrain naturel de l'imagination. Un lieu où l'on s'arme pour supporter le silence inaltéré de l'univers qui dépasse notre imagination, et pour ne pas succomber à la panique ou à la menace d'une dissolution. Ce silence des abysses qui nous est étranger, mais auquel nous appartenons aussi. Cette part de nous qui est abandonnée à de purs possibles, à des obsessions irrépressibles de toutes sortes, à l'incertitude de la peur, et dont nous nous protégeons à tort, par convention.

En plus du sérieux et de l'honnêteté dans le travail, il y a autre chose qu'on pourrait être tenté de cacher sous des intentions nobles et idéalistes, mais qui au fond sert aussi notre besoin irrépressible d'expériences extrêmes. Certains de ces expériences sont rudés, mais quand on regarde en arrière, on s'aperçoit qu'on a gagné en endurance, dans l'attente du prochain défi. C'est une façon d'explorer ce lieu étrange qu'on appelle la réalité. Bien sûr, nous avons des engagements, des attentes, des partenaires et toutes sortes de responsabilités, mais quelle que soit l'issue du projet, je suis ici avant tout pour le plaisir. Je pense que je ne peux plus distinguer la vie de ce que je fais. Je suis content de ne pas travailler à Wall Street parce que j'aurais une vie plus courte. Disons simplement que la création nait d'un fait qu'on a beaucoup de mal à envisager : qu'il faut donner une chance à ce qu'il y a de plus précieux au monde.

Edoardo XII in The Burial of the Dead (2016), ce dernier étant un dispositif vidéo à trois écrans commandé pour la Biennale de l'Image en Mouvement, illustre très bien ce que je viens de dire. À 5100 mètres d'altitude, le campement tentaculaire de la mine d'or de La Rinconada, dans les Andes, à la pointe sud-est du Pérou, est l'installation humaine permanente la plus élevée au monde, avec une population de près de trente mille âmes, dont la vaste majorité est désespérément démunie. Ici, presque tout, mines et mineurs, est informel, ce qui, selon les dictionnaires, est un doux euphémisme pour légal. La plupart des mineurs ne reçoivent aucun salaire, encore moins de bénéfice, mais travaillent selon un système archaïque appelé camborio : trente jours de travail non payé suivi d'un seul jour de frénésie pendant lequel les mineurs peuvent garder pour eux la quantité d'or qu'ils ont réussi à extraire de la quantité de minerais qu'ils ont pu transporter. Tout a commencé en 2013, avant la première de No Man's Land à Berlin. Un mal : « La Rinconada » : une idée : celle de faire un film là-bas ; une certitude : aucune garantie de succès, étant donné l'altitude qui constitue un véritable défi, et le caractère hors-la-loi de ce site. Mais espérons quand même de trouver des financements, tentons notre

Biennale de l'Image en Mouvement

João Ribas

Salomé Lamas

JR
Vous travaillez de façon très intimiste, avec une petite équipe et vous êtes prioritaire, littéralement, dans les paysages que vous donnez à voir.

SL
Il faut être très sûr de soi, pour convaincre les gens de vous suivre. Sur certains projets, tout commence au bluff.

chance, et j'y ramènerai un film. Facile. Bref, j'apprends que National Geographic veut faire un sujet là-bas. Sous l'angle du drame social. Pas une fois cette idée de drame social ne m'avait traversé l'esprit.

Je crois que maintenant, les gens avec qui je travaille s'attendent un peu. Je suis une très mauvaise joueuse de poker. Vous avez déjà vu cela dans mes films. J'ai constaté qu'à plusieurs reprises, certaines personnes qui étaient amenées à prendre plus de risques que d'autres, et sans avoir été prévenues à l'avance, étaient non seulement partantes mais en redoublant, et je leur en suis reconnaissant. Pourquoi que ça dure ? Je pense que dans la plupart des cas, il est très clair dès le départ que les choses peuvent « mal tourner », et nous acceptons ces conditions comme faisant partie du projet.

Et puis, nous avons plusieurs plans B. C'est ça, de travailler avec un bon producteur. Sur le tournage de Edoardo XII, ma société de production D Som e a Furia, à Lisbonne, n'aurait pas été très surprise si j'avais appelé en disant « on arrête tout, on renvoie l'équipe ». Pour être tout à fait honnête, c'est ce qui a failli se passer peu après la deuxième semaine de tournage, mais on a continué, et j'ai trouvé une solution, grâce à mon équipe.

Ce n'est pas toujours la même échelle, le même investissement, en personnel et en budget, en fonction des projets. Il y a des projets de moindre envergure que l'Edoardo ou que je coproduis. Disons qu'au bout du compte, je suis extrêmement pragmatique, l'essai de prévoir tous les scénarios possibles, et toutes les conséquences imaginables. Il faut être honnête, lucide, jouer franc-jeu, et trouver les bons partenaires.

JR
Vous avez travaillé à la fois dans le milieu des galeries et dans un contexte plus cinématographique. Est-ce que ces deux domaines ont des qualités propres qui vous intéressent ?

SL
Je dirais que chaque projet trouve son propre espace, et que certains de mes travaux ont une souplesse qui leur permet de s'adapter aux deux.

Mais si je montre exactement le même travail dans les deux contextes, la perception du spectateur ne sera pas la même. Les codes sociaux qui régissent la façon dont on circule, dont on se comporte dans ces deux espaces que sont le cube blanc et la boîte noire ne sont pas les mêmes. Ils ont chacun leur tradition, leur histoire, leur impact culturel. Les notions d'« expanded cinema » ou d'installation vidéo dans l'espace d'une galerie conduisent à différentes expériences, qui produisent des effets différents et, au final, ne touchent pas le public de la même façon. Un dispositif vidéo à un seul écran est plus facilement adaptable à différents espaces, tandis qu'une installation vidéo à plusieurs canaux de projection est généralement plus spécifique au site pour lequel elle a été conçue, ou le dispositif a été mûrement pensé pour un espace en particulier.

Dans une galerie ou sur une scène de théâtre, les intentions sont identiques. Les outils et les moyens mis en œuvre pour interroger la réalité sont les mêmes, seuls les formats et les dispositifs d'exposition diffèrent. En général, je fais appel à un designer pour dessiner l'espace de la galerie, et ensemble, on essaie de diriger et de prévoir les mouvements des spectateurs. C'est amusant, et côté budget, je ne suis pas prête à transiger sur cette phase de conception : je préfère encore adapter mon projet au budget pour que cela soit possible.

244 245

Biennale de l'Image en Mouvement

João Ribas

Salomé Lamas

The Burial of the Dead (2016), BIM 2016 Biennial of Moving Image Catalogue, Switzerland – Italy 2017

Mousse Magazine

Salomé Lamas & João Ribas

João Ribas: There is in your work a strong interest in narrative that seems to go beyond any strict definition between fiction or documentary, or any such distinction of genres, such that your films seem to exist at the limit of where one begins to take over or supersede the other....

Salomé Lamas: For me non-fiction is a sort of a *rabbit hole*. I guess also another notion I'm very much attached to, is the idea of *parafiction*. Today we welcome the make-believe and the plausibility against authenticity. Indeed non-fiction cinema interests me, the limits of documentary filmmaking, this idea that we believe in the documentary because it is constructed upon reality...let's say if we are to build a brick wall erected upon the real, with its foundations on reality, but if we are to remove one or two fictional bricks of this wall, the wall will crumble down, so we do need these fictional bricks to believe in what is placed in scene. Therefore we end up slightly reflecting on how vectors such as storytelling, memory and the concept of history...how can we erase these vector's borders? Once again, how can we liquidate the border between fact and fiction? How can we play with it? How can we reveal these mechanisms?

There is no clear judgment or statement being drawn on reality, there is an assemblage of proposals to be thought by an audience.

JR: There is also a tension in films in like El Dorado between what we associate with the documentarist image, and the narrative power of social reality, where storytelling and witnessing are intertwined...

SL: I guess one should think twice about imprinting a new image because of the overall saturation of visual stimulus in contemporary societies.

When we create images we are somehow translating the language of things into a graphical language I personally like to reflect upon what is at stake in that process. What distinguishes an image from its phenomenological *essence* is its historical mark.

Each present is determined by its synchronous images; each 'now' is a 'now' of categorical reference. One in which truth is filled with time until its explosion. This explosion is the *intentio* death, which coincides with the truth birth of the historical time. The image is the suspended dialectic between past and present, containing on a higher level the mark of the critical moment (borrowing from Walter Benjamin).

JR: The ethics of representation...

SL: I guess that is the only possible way for me to bear the fact that I make non-fiction films, and to accept that making non-fiction is a *dirty job*. Although there are ways to seek some kind of balance, and that is also why sometimes my presence in the work is more noticeable than in others. Every filmmaker that works with non-fiction film has to deal with core ethical questions. The way to deal with it cannot be separated from the way you inhabit the world in general, the way you shape your relationships and your moral behaviors... Non-fiction filmmakers are responsible for what they represent, while turning personal affairs into public discussion.

They are responsible for their subjects, and for their audiences. There are always judgments involved. Filmmakers need to weigh their actions, and they should regard production, representation, and reception as social acts that bear ethical consequences. More than simply asking if what we see and hear is credible or Authentic, we should think about what interests a documentary serves, what impact it might have on the spectators, and whether or not it takes into account the welfare of the people represented. Let's think of the following vectors, and how they are related to the filmmaker: sponsors, subjects, and spectators. What is the power voltage contained in each of these links? Are honesty and fidelity equal to responsibility? No. There are different ways of pursuing equilibrium, but seeking a balanced methodology will only allow the gap to be clearer. This gap has a place to be, and it is precisely on nobody's land that the film can exist as an autonomous piece. If on one hand we might be tempted to examine documentary as an exercise of political and social power, on the other hand it does not mean that the filmmaker is the wolf—and this is precisely where it becomes interesting, if we regard power relations as productive as they might be. As a filmmaker one should be aware that a film allows the spectator to know as much about the represented object as about the maker itself. Therefore it is pertinent that the maker finds an authorial and ethical voice.

JR: The films are in some sense portraits...

SL: Non-fiction tells you as much about its subjects as it tells you about its

maker.

JR: The structure of a lot of your work I think stems from how personal biography or experience intersects with larger historical, political or economic narratives, telescoping out from the individual experience of one person and how that life is a vector for a larger context...take for example the protagonist of *No Man's Land*..

SL: What is entitled to be preserved? How can ordinary people or researchers access this patrimony? Who owns it? Why are some sections confidential? Who determines confidentiality? How high are the preservation and storage costs? What gets lost when Alexandria's Library burns down? It is humanity's duty to collect, and to remember, but collections are limited, and someone is curating.

We cannot break away history from trauma, and the question raised could be how can one represent the trauma? Something that is both unforgettable and unmemorable, isn't it a process of desire? There are incredibly beautiful archive projects around the world. As a kid, and still today, whenever I visit a foreign country I look for the national archive. Accessibility differs enormously from country to country. Yet we, if there is still a "we" to protect, cannot forget...

'No Man's Land' focuses on the *testimony* of Paulo de Figueiredo where he narrates his involvement as a hired killer for special military forces during the Portuguese colonial war, the part he played in the GAL (Antiterrorist Liberation Group), a death squad illegally established by the Spanish government to annihilate high officials of ETA, and his work as a mercenary for the CIA in El Salvador. Rather than being interested in affirming the veracity of the historical record or in proving an official narrative, 'No Man's Land' dwells in the present moment of witnessing, the space inhabited by the performance of a memory. I tried to create a set or a stage where information or document are peripheral to the question of how one plays out and affirms as history his own personal truth.

JR: The films also revolve around a set of relations to be filmed, in that they seem to create a space for a narrative to emerge.

SL: My work dwells on a couple of main lines...one of these lines could be understood as some kind of flexible account upon the notion of *limit – border – margin*. I tend to flirt with *crystal-images* and *crystal-images* are unpredictable. Images contain riddles, they set traps and many times we are asked if we are not only casting an illusion.

I like to lay the cards in front of the viewer, to play a fair game, but I'm also forcing the viewer to be active in its reading. One has to cherry-pick the way one wants to perceive what is being presented on screen, you must struggle with your preconceptions, ethics, judgements, etc. It is never about the edges, let's say, black/white. It is about the grey areas. Lazy people are a drag.

'To wait' is also a constant in my practice. There is a key question: How long do I have to wait until reality becomes extraordinary? Sometimes it comes to: How much time can the production buy?

I'm not mystical but I have strong convictions that filmmaking besides being the work of a shoemaker it is also an act of faith and that each image is able to communicate its duration in juxtaposition with what comes before and after...I also believe in honesty and if your aim is to challenge or even to trick the viewer you should be explicit about what you are doing to people (even if you just reveal it in the end).

JR: This has an interest relation to cinematic time...There is for example the long take in *Eldorado XXI*...

SL: That brings us to how duration affects our perception of the images, how the viewer perceives repetition within the extended image, and how that is linked with the notion of becoming. How duration within a particular image is also unveiling the creative process, the waiting methodology, the falling, unveiling freedom and fidelity—two concepts that would never go together except in the act of translating reality.

In '*Eldorado XXI*' there is a take close to one hour, fix, (I let the camera roll for two hours in fact) while dozens and then hundreds of miners, groaning under the weight of their burdens, trudge by in squeezed files, some heading up and others down the narrow pitched mountain path, the scene starting out in thin crepuscule but persisting into pitch black (by the end all we see are the crisscrossing beams of the workers' hardhat headlamps), the soundtrack consisting of the crunch of their boots played off against stray wisps of audio testimony and wafting passages of radio banter. Lawrence Weschler described it as 'A human antfile. A Dantesque Escherscape: Möbian Sisyphi.' – I like to think of it as a fake *trompe l'oeil*.

JR: Can you talk about your interest in particular places and landscapes: Transnistria, a Peruvian Mine, a holiday camping site...

SL: I do not have an easy relationship with borders. They frighten me and they unnerve me, I have been searched, provoked, delayed time and time again for having had the senselessness to cross a few meters of land. Borders are bureaucratic lines, authoritative and enemy. Their existence is routinely criticized by academic geographers that portray them as hostile acts of exclusion; nonetheless, in a world without borders, where would we escape to? Where would it be worth going to?

I usually address realities that present some kind of discomfort, *nowhereness* places, or territories hard to describe in one blow.

No man's land is the natural land of the imagination. It is in that non-place that we arm ourselves with to withstand the immaculate silence of the universe that goes beyond our own imaginations, so that we do not succumb to pure panic and to the threat of dissolution. Silence from the abyss that is foreign to us but to which we also belong to. In this part of us that is abandoned to the

pure possibilities, the unsubdued obsessions of any form, the inertia of fear, from which we falsely protect ourselves by convention.

Besides the seriousness, and the honesty of the work, there is also something that you might be tempted to mask with idealistic and noble intentions, but that deep down also serves your self-obsessed needs for challenging experiences. Some of these interactions are tough but, when you look back at them, you realize that you have grown more capable of enduring the next challenge. It is a way of visiting this strange place we all call reality. Of course there are work commitments, expectations, partners, and further responsibilities, but no matter the outcome of the projects, I am there first for the ride. I guess I can no longer distinguish life from what I do. I am happy because I'm not working on Wall Street or I would have a shorter life... Let's just say that creation arises from a fact that is intolerable to suppose, that what is the most precious in the world should be given a chance.

'Eldorado XXI' (2016) and the 'The Burial of the Dead', the 3-channel drift commissioned by Centre d'Art Contemporain Genève are indeed great examples of these. At 5100 meters (16,700 ft.), the sprawling Andean goldmining encampment at La Rinconada, in the southeastern corner of Peru, is quite simply the highest-elevation permanent human settlement in the world, encompassing a population of close to 30,000 souls, the vast majority of them desperately unfortunate. Nearly all the mines and miners there are 'informal,' a term that critics consider a euphemism for illegal. Most don't pay salaries, let alone benefits, but run on an ancient labor system called *cachorro*. This system is usually described as thirty days of unpaid work followed by a single frantic day in which workers get to keep whatever gold they can haul out for themselves. – It all started in 2013 before the premiere of 'No Man's Land' in Berlin – one word 'La Rinconada' – one thought I want to make it up there – one request, I know there are no guarantees (the altitude challenge, the outlaw specificities of the site equipment) but let's try to find the resources, let's give it a try, I'll bring back a film – easy – anyhow it would be a very long story to tell you know...it has come to my understanding that the National Geographic wants to do something up there, they want to look for the social drama – not even once it had crossed my mind to create a social drama...

JR: Your process is also very intimate in a way, working with a small crew and being present within the literal landscape and thematic landscape you are trying to depict...

SL: One must be very assertive, and convince people to go along with you. Some projects start with a bluff. I guess that by now the people I have been working with, are already expecting the bluff. I am a very bad poker player. You have noticed that already in my films. I am very grateful that in a number of occasions, some facing more risks and unpredictability than others, the crew not only "paid to see," but also tripled the bet... Let's see for how long I can keep up with the trick! I think that in most cases it is clear since the beginning that things can 'go wrong', and we accept those conditions as part of the project. We also build up strategies to reinforce multiple backup plans.

For me that is also what it means to work with a good producer. It would not have been that unexpected if suddenly, while shooting *Eldorado XXI*, I had to call up the production company (O Som e a Fúria) in Lisbon, to say that we must send the crew home. Honestly, this phone call was about to happen shortly after the second week of the shooting, but we kept going, and I found another way out, thanks to the crew I was working with. These projects have different scales and commitments, crew and budget wise. There are smaller scale projects that I self produce or that I co-produce. So let's say that, on top of all, I am extremely pragmatic, and do try to predict all case scenarios, and possible consequences. You just have to be very honest, lucid, play an open game, and find the right partners.

JR: You've often worked with both the gallery context and the more traditional cinematic context, is there something particular to either that interests you?

SL: I would rather tell you that each project encounters its own space and that some of my work has the flexibility of fitting both; but we should be aware that even if we were screening the exact same work the perception of the viewer would be different in each case. The codes on how to circulate, occupy and behave in the space of the *white cube* vs. the *black box* are different. It's tradition, history and social impact is different. I mean that notions of expanded cinema or video installations on gallery spaces lead to different work experiences that lead to different outcomes, that lead to different ways of reaching an audience.

Also one thing are single-channel works that travel easily from space to space another case is a brand new video installation, multi-channel, usually site specific or with a carefully planed build up and display in the space that is taking.

In both the gallery and the theater space, the intentions are identical, the tools and means to address reality are the 'same', and only the formats and exhibition displays are different. I usually invite a designer to outline the gallery space. I'm very picky with beamers and the machinery used, and try to direct and predict the spectators' movements, etc. It is fun, and I tend not to compromise on how the installation should be set up budget wise, (I would rather design a project that suits the available budget or conditions).

Salomé Lamas (1987) studied cinema in Lisbon and Prague, visual arts (MFA) in Amsterdam and is a Ph.D candidate in film studies in Coimbra.

She is the author of 'The Community' (2012), 'Encounters with Landscape 3x' (2012), 'VHS: Video Home System' (2010-2012), 'Terra de Ninguém' (2012) (En. 'No Man's Land'), 'Theatrum Orbis Terrarum' (2013), 'Le Boudin' (2014), 'The Tower (2015)', North: Trial by Fire (2015) 'Mount Ananea (5856)' (2015), 'Eldorado XXI' (2016), The Burial of the Dead (2016), 'Coup de Grâce (2016), 'Extinction' (in finalisation), among others art projects.

Her work has been awarded and showcased both in art venues and film festivals such as Berlinale, NIMK Netherlands Instituut voor Mediakunst, Calouste Gulbenkian Foundation, BAFICI, Museo Nacional Centro de Arte Reina Sofia, Mar del Plata Film Festival, FIAC, Rome Film Festival, MNAC –

Museu do Chiado, DocLisboa, Documenta Madrid, MoMA, Lincoln Center, Guggenheim Bilbao, Pacific Film Archive - Berkeley University, Harvard Film Archive, Museum of Moving Images NY, Jewish Museum NY, Fid Marseille, Arsenal Institut fur film und videokunst, Cinema du Reel, Viennale, Hong Kong FF, MALBA, UCLA Hammer Museum, Serralves Contemporary Art Museum, La Casa Encendida, CPH:DOX, Centre d'Art Contemporain Genève,

Bozar - Centre of Fine Arts, TABAKALERA, Les Rencontres Internationales - Nouveau Cinema et Art Contemporain etc.

Lamas was awarded fellowships at the Rockefeller Foundation Bellagio Center, Bogliasco Foundation, MacDowell Colony, Yaddo, DAAD Berliner Künstlerprogramm, etc.

She collaborates with the production company O Som e a Furia and is represented by Miguel Nabinho Gallery - Lisboa 20.

João Ribas (1979) is Deputy Director and Senior Curator of the Serralves Museum of Contemporary Art, Porto. He was previously Curator of the MIT List Visual Arts Center and of The Drawing Center, New York. Ribas is the winner of four consecutive AICA Exhibition Awards (2008–11) and of an Emily Hall Tremaine Exhibition Award (2010) and his writing has been featured in numerous catalogs and publications such as Artforum, Mousse, Afterall, Artnews, Frieze, and ArtReview among others. His recent publication, *In the Holocene*, is published by Sternberg Press (2015).

Text originally published by Mousse Magazine publication, September, 2016.





Salomé Lamas, *The Burial of the Dead*, 2016. Installation view at Biennale of Moving Images, Faena Bazaar – Miami Beach, USA 2017 Courtesy of the artist, Centre d'Art Contemporain Genève, and Faena Art. Photo: Oriol Tarridas